



US008979938B2

(12) **United States Patent**
Linares

(10) **Patent No.:** **US 8,979,938 B2**
(45) **Date of Patent:** **Mar. 17, 2015**

(54) **ARTIFICIAL KNEE IMPLANT INCLUDING LIQUID BALLAST SUPPORTING / ROTATING SURFACES AND INCORPORATING FLEXIBLE MULTI-MATERIAL AND NATURAL LUBRICANT RETAINING MATRIX APPLIED TO A JOINT SURFACE**

(58) **Field of Classification Search**
CPC A61F 2/32; A61F 2/34; A61F 2002/3208
USPC 623/14.12, 18.11, 20.14, 20.17, 22.11, 623/23.39, 20.4, 20.41, 22.15, 22.17, 22.21, 623/19.12, 20.22, 20.23, 20.28, 22.24, 623/21.13, 21.16, 23.4
See application file for complete search history.

(75) Inventor: **Miguel A. Linares**, Bloomfield Hills, MI (US)

(56) **References Cited**

(73) Assignee: **Linares Medical Devices, LLC**, Auburn Hills, MI (US)

U.S. PATENT DOCUMENTS

(*) Notice: Subject to any disclaimer, the term of this patent is extended or adjusted under 35 U.S.C. 154(b) by 799 days.

2,667,644 A 2/1954 Johnson
3,651,521 A 3/1972 Devas
3,798,679 A 3/1974 Ewald
3,875,594 A 4/1975 Swanson
3,964,106 A 6/1976 Hutter, Jr. et al.

(Continued)

(21) Appl. No.: **12/266,695**

FOREIGN PATENT DOCUMENTS

(22) Filed: **Nov. 7, 2008**

JP 07116184 A 5/1995

(65) **Prior Publication Data**

US 2009/0125108 A1 May 14, 2009

Primary Examiner — Thomas J Sweet
Assistant Examiner — Seema Mathew

Related U.S. Application Data

(74) *Attorney, Agent, or Firm* — Gifford, Krass, Sprinkle, Anderson & Citkowski, P.C.; Douglas J. McEvoy

(60) Provisional application No. 60/986,486, filed on Nov. 8, 2007.

(57) **ABSTRACT**

(51) **Int. Cl.**
A61F 2/32 (2006.01)
A61F 2/38 (2006.01)
A61F 2/08 (2006.01)
A61F 2/30 (2006.01)

An artificial joint associated with an implant having a pair of three dimensional and structurally extending bones, each defining a contoured and opposing end face and collectively defining a joint location. A plasticized layer is applied to an end face of each bone and coacts in substantially frictional reducing fashion with an opposing end face of a further selected bone. The plasticized layer further includes at least a plurality of projecting contact locations, between which are defined a network of valleys for receiving, supporting, and distributing a lubricant across a surface area associated with the layer.

(52) **U.S. Cl.**
CPC ... *A61F 2/38* (2013.01); *A61F 2/08* (2013.01); *A61F 2/30965* (2013.01); *A61F 2002/30673* (2013.01); *A61F 2002/30934* (2013.01); *A61F 2002/30971* (2013.01)
USPC **623/22.15**; 623/14.12; 623/18.11; 623/19.12; 623/20.22

4 Claims, 5 Drawing Sheets

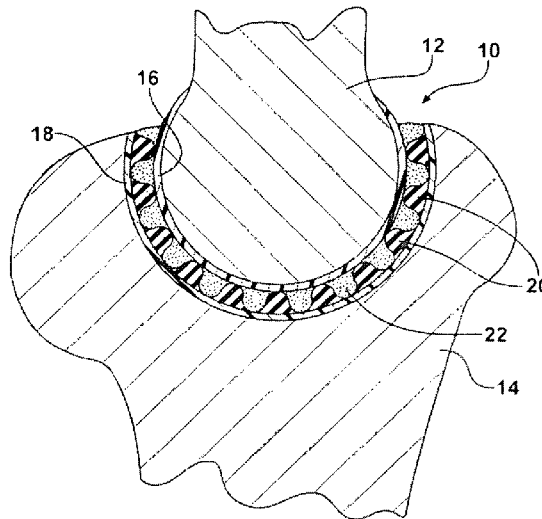

(56)

References Cited

U.S. PATENT DOCUMENTS

4,055,862	A *	11/1977	Farling	623/18.11	6,682,567	B1 *	1/2004	Schroeder	623/22.24
4,215,439	A	8/1980	Gold et al.		6,692,679	B1	2/2004	McNulty et al.	
4,231,122	A	11/1980	Koeman		6,723,102	B2	4/2004	Johnson et al.	
4,328,593	A	5/1982	Sutter et al.		6,800,298	B1	10/2004	Burdick et al.	
4,367,562	A	1/1983	Gauthier		6,800,670	B2	10/2004	Shen et al.	
4,538,305	A	9/1985	Engelbrecht et al.		6,811,568	B2	11/2004	Minamikawa	
4,714,477	A	12/1987	Fichera et al.		6,818,172	B2	11/2004	King et al.	
4,778,474	A *	10/1988	Homsy	623/22.14	6,866,685	B2	3/2005	Chan et al.	
4,813,961	A *	3/1989	Sostegni	623/23.39	6,962,607	B2	11/2005	Gundlapalli et al.	
4,950,298	A	8/1990	Gustilo et al.		7,044,983	B1	5/2006	Cheng et al.	
4,964,868	A	10/1990	Bloebaum		7,066,958	B2	6/2006	Ferree	
4,990,161	A	2/1991	Kampner		7,077,867	B1 *	7/2006	Pope et al.	623/20.14
5,007,934	A	4/1991	Stone		7,087,091	B1	8/2006	Chen et al.	
5,021,061	A	6/1991	Wevers et al.		7,109,181	B2	9/2006	Cowlen et al.	
5,092,898	A	3/1992	Bekki et al.		7,148,209	B2	12/2006	Hoemann et al.	
5,171,325	A	12/1992	Aulie		7,175,666	B2	2/2007	Yao	
5,197,987	A *	3/1993	Koch et al.	623/20.28	7,179,298	B2	2/2007	Greenlee	
5,358,525	A *	10/1994	Fox et al.	623/14.12	7,186,364	B2	3/2007	King et al.	
5,389,107	A	2/1995	Nassar et al.		7,331,995	B2	2/2008	Eisermann et al.	
5,462,362	A	10/1995	Yuhta et al.		7,384,430	B2	6/2008	Greer et al.	
5,480,448	A *	1/1996	Mikhail	623/22.24	7,578,851	B2	8/2009	Dong et al.	
5,509,934	A	4/1996	Cohen		7,771,485	B2	8/2010	Grunde	
5,549,697	A *	8/1996	Caldarise	623/22.26	7,780,738	B2	8/2010	Khandkar et al.	
5,549,699	A *	8/1996	MacMahon et al.	623/22.21	7,803,193	B2 *	9/2010	Steinberg	623/20.21
5,549,700	A *	8/1996	Graham et al.	623/22.14	8,257,444	B2 *	9/2012	Linares	623/18.11
5,553,476	A	9/1996	Oehy et al.		8,556,981	B2 *	10/2013	Jones et al.	623/20.17
5,571,193	A	11/1996	Kampner		2002/0183845	A1 *	12/2002	Mansmann	623/13.11
5,593,445	A	1/1997	Waits		2003/0065401	A1	4/2003	Amrich et al.	
5,641,323	A *	6/1997	Caldarise	623/22.18	2003/0114935	A1 *	6/2003	Chan et al.	623/22.21
5,645,594	A *	7/1997	Devanathan et al.	623/11.11	2003/0216669	A1	11/2003	Lang et al.	
5,645,601	A *	7/1997	Pope et al.	623/23.39	2004/0024460	A1	2/2004	Ferree	
5,662,158	A	9/1997	Caldarise		2004/0068322	A1	4/2004	Ferree	
5,676,702	A	10/1997	Ratron		2005/0055100	A1	3/2005	Lewis et al.	
5,702,476	A	12/1997	Limacher et al.		2005/0149199	A1 *	7/2005	Steinberg	623/22.23
5,728,175	A	3/1998	Rincoe		2005/0171604	A1	8/2005	Michalow	
5,800,566	A	9/1998	Gramnas		2005/0192672	A1	9/2005	Wyss et al.	
5,879,406	A	3/1999	Lilley		2005/0192674	A1	9/2005	Ferree	
5,916,269	A *	6/1999	Serbosek et al.	623/22.24	2005/0202371	A1 *	9/2005	McGuire	433/201.1
5,921,358	A	7/1999	Gramnas et al.		2005/0287187	A1	12/2005	Mansmann	
6,045,581	A *	4/2000	Burkinshaw	623/18.11	2006/0015186	A1	1/2006	Isaac	
6,129,765	A *	10/2000	Lopez et al.	623/22.15	2006/0173542	A1 *	8/2006	Shikinami	623/14.12
6,165,223	A	12/2000	Metzger et al.		2007/0100450	A1 *	5/2007	Hodorek	623/14.12
6,258,126	B1 *	7/2001	Colleran	623/20.29	2007/0179613	A1	8/2007	Heinz	
6,290,727	B1 *	9/2001	Otto et al.	623/22.21	2007/0287027	A1	12/2007	Justin et al.	
6,368,354	B2 *	4/2002	Burstein et al.	623/22.28	2008/0033567	A1	2/2008	Stchur	
6,398,815	B1	6/2002	Pope et al.		2008/0288081	A1 *	11/2008	Scrafton et al.	623/20.33
6,530,956	B1 *	3/2003	Mansmann	623/18.11	2009/0076605	A1	3/2009	Linares	
6,627,141	B2	9/2003	McNulty et al.		2009/0088846	A1 *	4/2009	Myung et al.	623/14.12
6,629,997	B2 *	10/2003	Mansmann	623/14.12	2009/0125108	A1	5/2009	Linares	
6,645,251	B2 *	11/2003	Salehi et al.	623/20.28	2010/0145451	A1 *	6/2010	Dee	623/14.12
6,660,040	B2	12/2003	Chan et al.		2011/0066243	A1 *	3/2011	Rivin et al.	623/14.12
					2012/0209396	A1 *	8/2012	Myung et al.	623/22.11
					2013/0231750	A1 *	9/2013	Taylor	623/22.21

* cited by examiner

FIG. 1

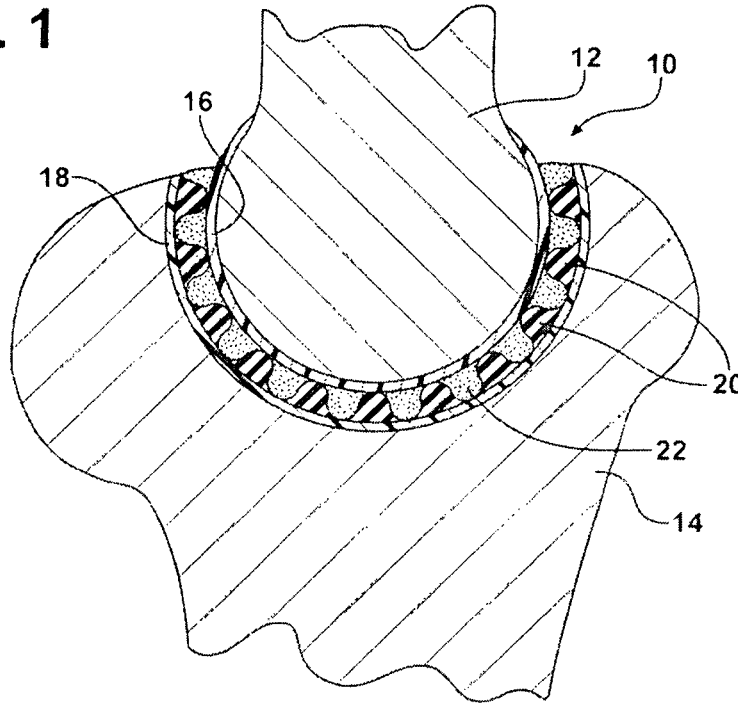
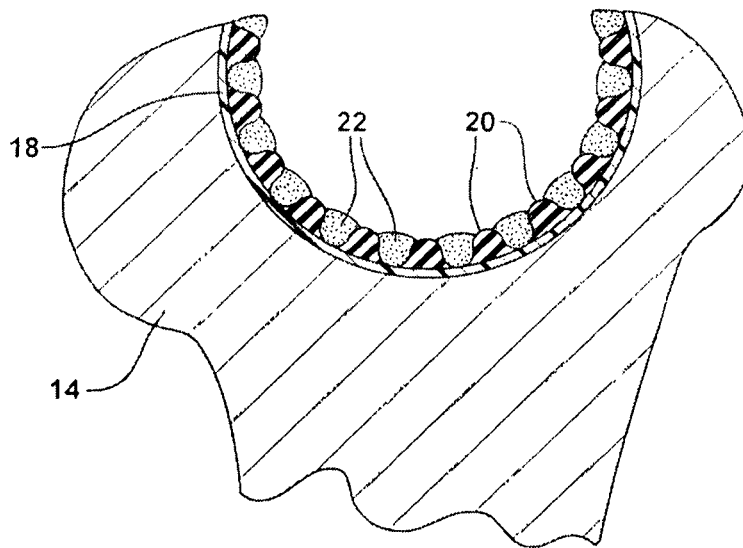

FIG. 2



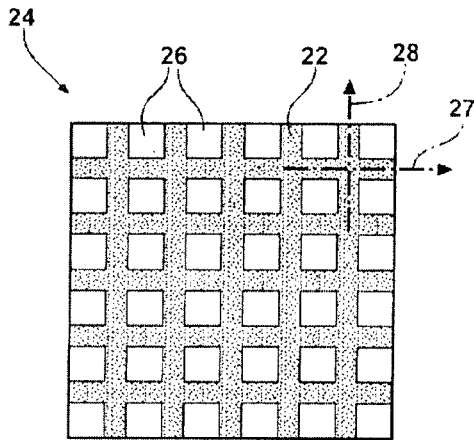

FIG. 3

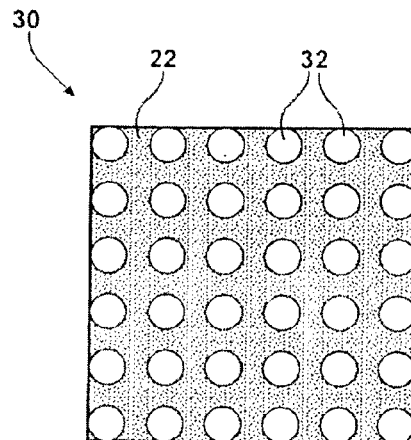

FIG. 4

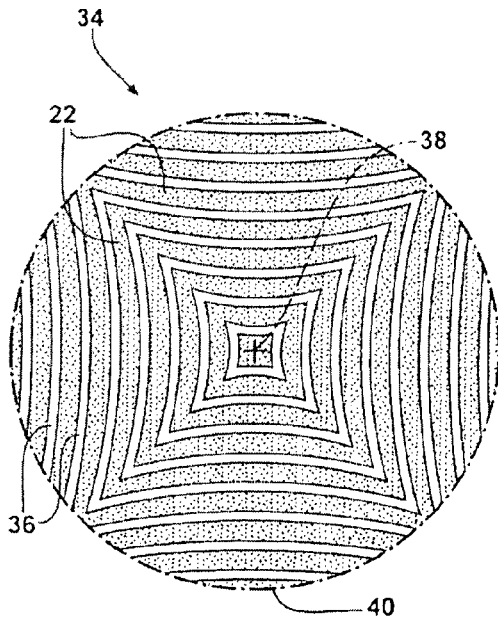

FIG. 5

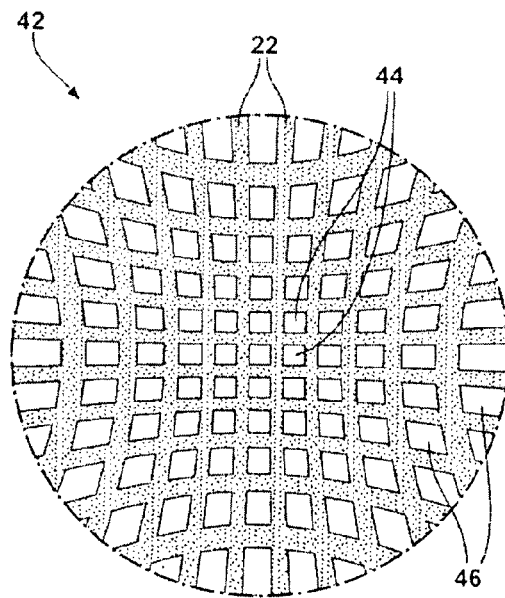

FIG. 6

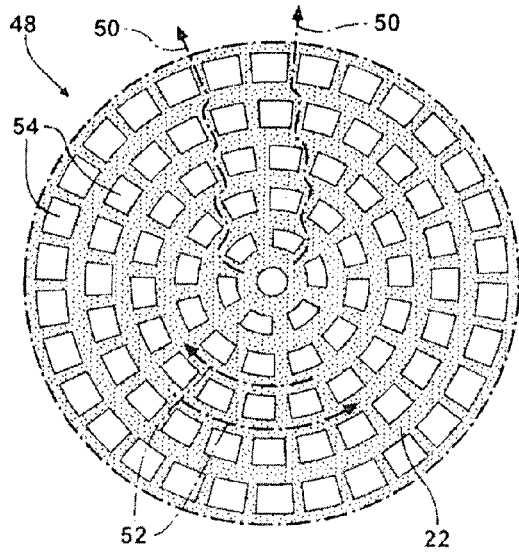

FIG. 7

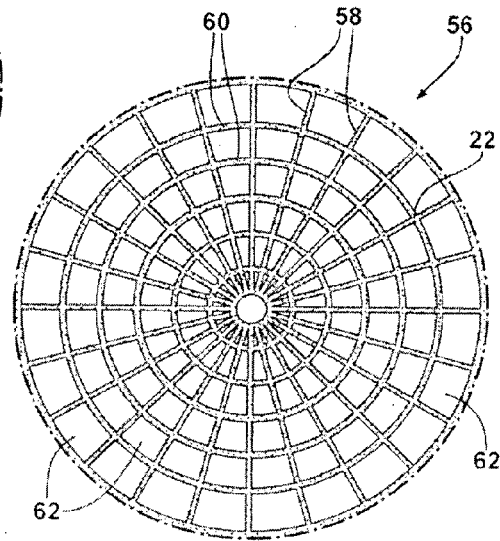

FIG. 8

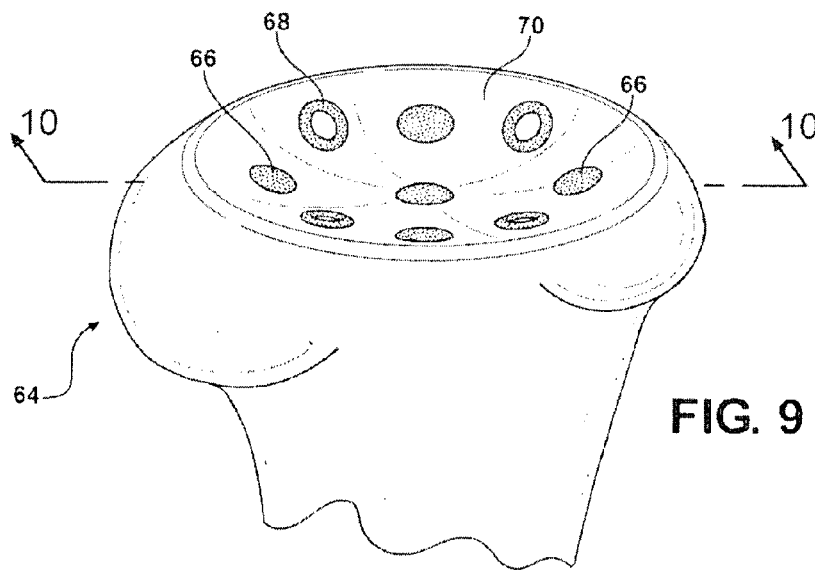

FIG. 9

FIG. 10

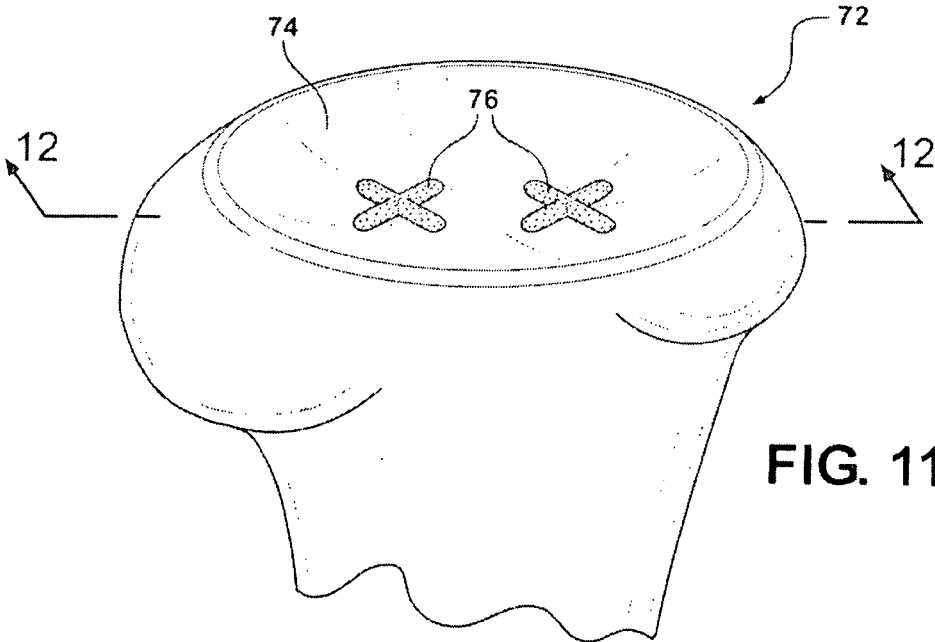
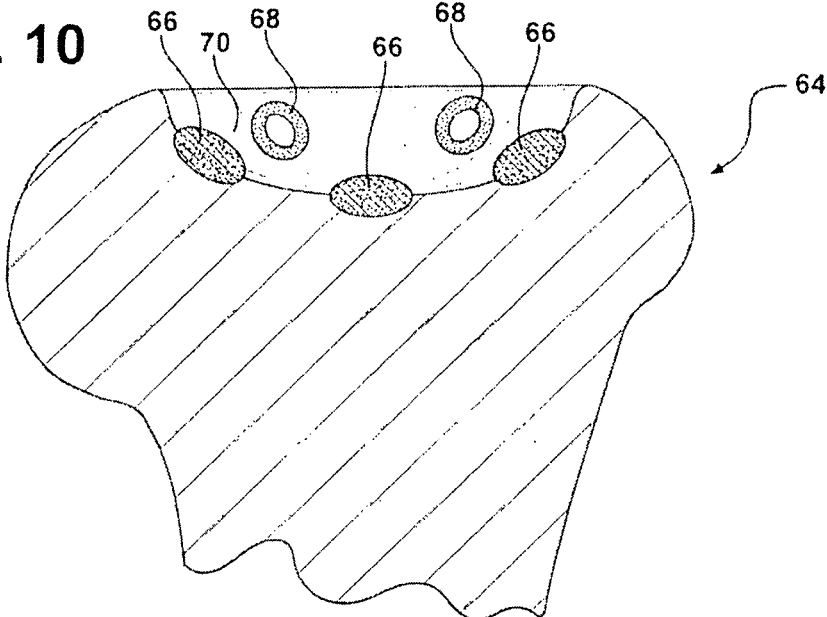
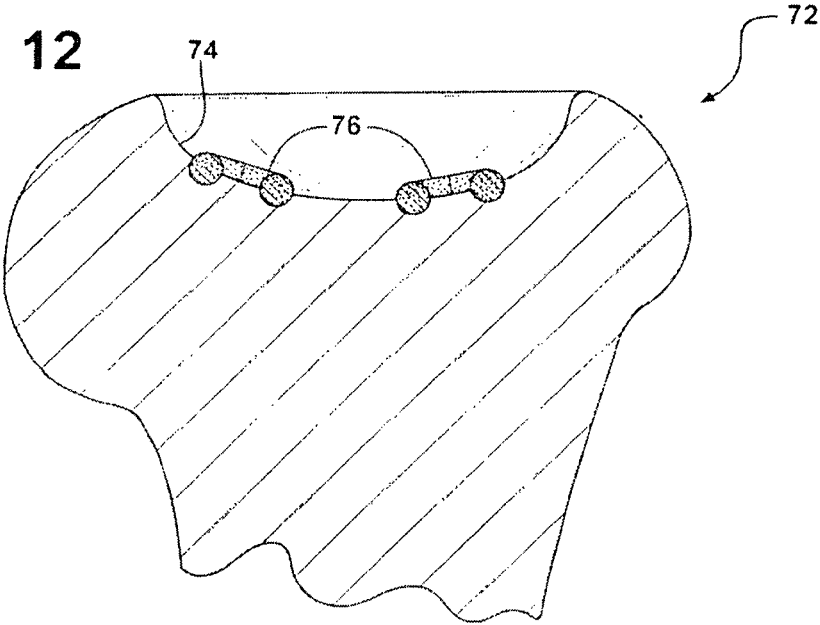

FIG. 11

FIG. 12



1

**ARTIFICIAL KNEE IMPLANT INCLUDING
LIQUID BALLAST SUPPORTING / ROTATING
SURFACES AND INCORPORATING
FLEXIBLE MULTI-MATERIAL AND
NATURAL LUBRICANT RETAINING
MATRIX APPLIED TO A JOINT SURFACE**

CROSS-REFERENCE TO RELATED
APPLICATIONS

This Application is a Non-Prov of Prov (35 USC 119(e)) application 60/986,486 filed on Nov. 8, 2007 and entitled ARTIFICIAL KNEE IMPLANT INCLUDING LIQUID BALLAST SUPPORTING/ROTATING SURFACES AND INCORPORATING A FLEXIBLE MULTI-MATERIAL AND NATURAL LUBRICANT RETAINING MATRIX APPLIED TO A JOINT SURFACE.

FIELD OF THE INVENTION

The present invention is an artificial implant for use with either real or artificial human bones. In particular, the implant of the present invention is an improvement over prior art implants, typically those constructed of a metallic or other synthetic material, in that it provides ballasting and frictionless support to opposing ends of first and second bones associated with such as a knee joint. In addition to providing support through the injection of ballasting fluid into a bladder defined between the bones, the present invention further provides a wide variety of additional structures for more effectively establishing cushioning and multi-directional support in the artificial joint area.

BACKGROUND OF THE INVENTION

The prior art is well documented with examples of artificial (or prosthetic) implant joints and related assemblies, the purpose for which being to replace an existing joint which has become worn through extended wear or irreplaceably damaged through disease or injury. One objective of such artificial joint implants, whether adapted for use with an existing bone remaining in the patient or as a component of one or more skeletal implants which includes a built-in joint, is in providing a desired amount of cushioning support. Examples of existing implant assemblies with built-in dampening means include, among others, the modular implant with micro-motion damper as set forth in U.S. Pat. No. 7,156,666, to Yao and the shock absorbent prosthetic hip joint of Nasser, U.S. Pat. No. 5,389,107. Additional references of note include the reduced-friction artificial joint set forth in Ferree 2004/0068322, as well as the composite prosthetic bearing in King U.S. Pat. No. 7,186,364.

SUMMARY OF THE INVENTION

The present invention discloses an artificial joint associated with an implant and having a pair of three dimensional and structurally extending bones, each defining a contoured and opposing end face and collectively defining a joint location. A plasticized layer, such as constructed of an antimicrobial plastic, is applied to an end face of each bone and, in use, coats in substantially frictional reducing fashion with an opposing end face of a further selected bone. The plasticized layers each further include at least a plurality of projecting contact locations, between which are defined a network of valleys for receiving, supporting, and distributing a lubricant across a surface area associated with the layer.

2

Additional features include the plasticized layer exhibiting a polymeric based mat exhibiting a selected length, width and thickness for filling a three dimensional area associated with the joint location. The bones exhibit a hardened, e.g. typically composite, plastic terminating in a cartilage mimicking softened end plastic layer, the mat securing to a selected plastic layer and such that a plurality of ridges formed with the mat define the contact locations for an opposing softened plastic layer associated with the other of the bones.

The mat may also include a first additive selected from at least one of a carbon and a graphite, and a second additive selected from at least one of a ceramic and a metal for providing the flexible and polymeric based mat with enhanced wear resistant properties. The opposing bone structure may also establish a joint selected from a group including at least one of upper/lower knee joint and an outer/inner ball and socket joint. The contact location valleys established by the surface secured mat structure allow for the distribution of lubricant passageways, these being selected from any of linear, radial, and concentric shapes and which allow for the lubricant to be evenly distributed across the mat surfaces and thereby establishing a consistently lubricated and friction reducing profile along all opposing contact surfaces between the bones defining the selected joint region.

A related version of artificial joint associated with an implant can include a pair of three dimensional and structurally extending bones, each defining a contoured and opposing end face, and which collectively defines a joint location. In this version, a plurality of pockets are defined in a selected and exposed end face of one of the bones, the pockets being selected from at least one of rounded, arcuate, doughnut and cross shaped configurations.

BRIEF DESCRIPTION OF THE DRAWINGS

Reference will now be made to the attached drawings, when read in combination with the following detailed description, wherein like reference numerals refer to like parts throughout the several views, and in which:

FIG. 1 is an illustration of an artificial knee implant according to a preferred embodiment of the present invention and exhibiting first (male) and second (receiver) bones, between which are disposed a rubberized and (self) lubricating mat configuration (such as ideally secured within an inner recess defining the second female bone) and further including an opposing surface mounted soft plastic liners associated with each of the hard plastic bones and, in cooperation with the mat configuration, establishing effortless contact with a second of the bones;

FIG. 2 is an enlarged illustration of a the receiver bone, and in particular showing the seepage inducing/self-lubricating mat consisting of such as three different intermixed materials inter-molded together and secured against the associated soft plastic liner, in turn sandwiched between the lubricating mat and the hardened, three dimensional plastic bone;

FIG. 3 is a first selected mat configuration according to one variant of the present inventions and showing a generally grid shaped pattern optimizing seepage and equal surface area distribution of either synthetic or natural/biological generated lubricants for assisting in long-term wear and support;

FIG. 4 is a second selected configuration characterized by such as a plurality of plastic or otherwise deformable portions which are entrained or otherwise embedded into a polymeric based and graphite and/or carbon entrained mat, and into which is further entrained a ceramic and/or metallic impregnate for increasing wear-resistant characteristics;

3

FIG. 5 is a yet further mat configuration exhibiting properties similar to that in each of FIGS. 3 and 4;

FIG. 6 is an additional mat configuration again referencing the alternate designs of FIGS. 3-5;

FIG. 7 is an end surface illustration of another mat configuration and employing a plurality of combined radially and concentrically configured fluid pathways;

FIG. 8 is a further mat configuration exhibiting aspects alternate to that shown in FIG. 7;

FIG. 9 is a perspective end view of such as a receiver bone end surface of a selected bone and including a plurality of fluid filled pockets/cavities according to a variety of different configurations;

FIG. 10 is cross sectional side view along line 10-10 of FIG. 9 and showing from another angle the fluid retaining pockets of FIG. 9;

FIG. 11 is a perspective end view of another variation of receiver bone end surface exhibiting cross-shaped fluid retaining pockets; and

FIG. 12 is a cross sectional side view along line 12-12 of FIG. 11 and showing from another angle the fluid retaining pockets of FIG. 11.

DETAILED DESCRIPTION OF THE PREFERRED EMBODIMENTS

Referring now to FIG. 1, a first embodiment is illustrated at 10 of an artificial knee/joint implant according to the present inventions. As previously described, the skeletal implant is intended to operate as a replacement for human bone and joint structure (such as resulting from disease, accidents, etc.) and which is further an improvement over existing prosthetic metal implants and the like.

In particular the several embodiments of the present invention as described herein disclose a multi-material configured mat structure, this exhibiting such as a generally plastic/polymer based material exhibiting a generally planar and flexible/deformable construction, and into which is entrained smaller volumes (such as according to a graded particulate) of a graphite/carbon and a ceramic/metallic impregnate material. As will be further described, the construction of the flexible and joint located mat is such that it aggregates and evenly distributes across its surface area the natural lubricant fluids produced by the body. It is also envisioned that additional embodiments of the mat design can augment or (in certain instances) replace the natural fluid retention capabilities with a synthetic lubricant, and such as which can be introduced by external injection or internally provided secretion processes.

The knee and ligament embodiment featured at 10 exhibits first 12 and second 14 bones, these typically corresponding to a patient's upper and lower leg bones and which further define particularly configured and opposing/seating locations which is defined a joint region 16. As further understood, the bones 12 and 14 are typically artificial prostheses, these including such as plastic, metal or other suitable material constructions which exhibit the necessary properties of durability and resilience.

Referring again to FIG. 1, the implant generally referenced at 10 includes a first male bone 12 and a second female/receiver bone 14, and between which is disposed a rubberized and (self) lubricating mat configuration, such as in a preferred embodiment secured to an inner recess associated with the female bone 14. Each of the male 12 and receiver 14 bones are configured to mimic natural bone shaping for a given application and may be constructed from such as a hardened plastic.

4

Both the male and female joint defining and contacting surfaces further include a softened (cartilage replicating) plastic layer, see at 16 for male bone 12 and at 18 for receiver bone 14, and with the mat configuration, see at 20, being established therebetween. As will be described, the surface mounted soft plastic liners, associated with each of the hard plastic bones, and in cooperation with the lubricant inducing and distributing mat configuration, establishes substantially effortless contact along the joint location defined between the bones. As is also known, each of the plasticized layers, including the softened layers 16 and 18 as well as the mat configuration 20, may exhibit a specified shape and size and further can include such as an antimicrobial plastic.

Referring to FIG. 2, an enlarged illustration is shown of the receiver bone 14 only, and in particular showing the seepage inducing/self-lubricating mat, at 20, and consisting of such as three different intermixed materials inter-molded together and secured against the associated soft plastic liner 18, in turn sandwiched between the lubricating mat and the hardened, three dimensional plastic receiver bone 14. As described previously, the matrix composition of the mat 20 combines a variety of materials, e.g. such as again including a polymer based matrix into which is intermixed or otherwise entrained such as through a stamping, molding or other appropriate mixing process additional materials such as graphite/carbon fibers and/or ceramic/metallic additives, and in order to replicate human joint cartilage. While no specific dimensions are provided, it is generally understood that the mat 20 exhibits a suitable length, width and thickness (overall 3D configuration) such that it adequately replicates a replacement joint structure such as associated with a hip, knee, elbow, ankle or the like.

Fluid lubricant is generally shown at 22 in each of the several illustrations associated with the present inventions. As will be described in further detail, the lubricant 22 includes in a first embodiment a naturally producing lubricant associated with normal joint operation, the mat 20 construction being such that it collects (such as through natural seepage or aggregation) the lubricant across its surface area and, further by virtue of the ridge and valley configuration associated with a given mat, is capable of evenly distributing the lubricant along opposite contacting surfaces with the soft plastic layers 16 and 18 of the male 12 and receiver 14 bones. As further previously described, it is also envisioned that the lubricant 22 can also include such as synthetic fluid which is either pre-loaded into an interior ballast associated with the polymeric base substrate of the mat or, additionally or alternatively, is capable of being selectively and iteratively injected through such as a needle or the like and in order to refill or replenish the lubricant holding reservoir associated with the design.

Referring now to FIG. 3, a mat configuration is generally shown at 24 according to one variant of the present inventions, and showing a generally grid shaped pattern optimizing seepage and equal surface area distribution of either synthetic or natural/biological generated lubricants, again at 22, for assisting in long-term wear and support. The arrangement shown in FIG. 3 includes a plurality of individual, spaced apart and generally rectangular shaped polymeric based projections 26, between which are defined interconnected and plural x 27 and y 28 axis channels and through which the lubricant 22 is retained.

The mat construction 24 again incorporates select additives of carbon/graphite fibers, along with ceramic and/or metallic based additives (according to any of flake, granular or powder base) which are mixed or otherwise entrained into the base matrix and subsequently molded into the mat construction. In

5

use, and consistent with each of the multiple variants described herein, the projections 26 establish contact ridges, and which support contact locations with the joint defining end surface of the opposing bone (e.g. male hardened plastic bone 12 with softened cartilage defining end surface 16), concurrent with the lubricant defined passageways 27 and 28 providing enhanced and improved frictionless and wear resistant contact support.

FIG. 4 illustrates a second selected mat configuration 30, characterized by such as a plurality of plastic or otherwise deformable portions 32 which are entrained or otherwise embedded into a graphite and/or carbon entrained and polymeric based mat, and into which is further entrained a ceramic and/or metallic impregnate for increasing wear-resistant characteristics. While somewhat modified, the x and y interconnected channels (again at 27 and 28 in FIG. 3) are again provided for in FIG. 4, with the rounded configuration of the deformable portions 32 providing a modified arcuate/curved interconnecting nature of the distributed lubricant/fluidic medium 22.

FIG. 5 illustrates a yet further mat configuration 34, again exhibiting properties similar to that in each of FIGS. 3 and 4. Of note, the plasticized substrate is reconfigured as elongated and concentric ridges, see at 36, and such as are arranged with multiple (four as shown) interconnecting sides. The lubricant 22 fills a plurality of likewise four-sided and individual valleys established between each interconnected and multi-sided ridge, and along opposite sides of each elongated ridge, concentrically from a center-most location 38 to a generally outermost radial location 40. If desired, it is also understood that the valleys can be interconnected in certain instances, such as by sectioning portions of the ridges, and to thereby improved equalized lubricant fluid distribution.

Referring to FIG. 6, an additional mat configuration 42 complements the individual and alternate designs of each of FIGS. 3-5. The configuration 42 is similar in respects to that shown in FIG. 3 and includes a plurality of modified rectangular (e.g. such as a hybrid trapezoidal/parallelogram) shaped projections (and as compared to those shown at 26 in FIG. 3). The configuration of FIG. 6 is such that the individual projections are arranged according to a desired size and spacing (separation), in one application with smaller sized projections 44 approximate the center location and progressively larger sized projections 46 established towards the outer perimeter locations of the mat 42. Depending upon the sizing of the radially spaced projections, either consistent or progressively larger fluid/lubricant defining and intercommunicating passageways 22 can established towards the outer perimeter locations of the mat 42.

Referring now to FIG. 7, an end surface illustration is shown at 48 of another mat configuration, this employing a plurality of combined radially 50 and concentrically 52 configured fluid pathways. As with previous embodiments, multiple pluralities of multi (four) sided projections 54 can be provided, and as shown can exhibit varying sizes with a modified trapezoidal configuration when compared to that shown at 44 and 46 in FIG. 6. The individually defined projections 54 associated with the matrix composition of FIG. 7 each further exhibit arcuate inner and outer edge surfaces, these establishing the concentric fluid pathways 52, it further being understood that a base surface supports and interconnects all of the projections 54, and upon which the interconnected fluid passageways 52 and 54 are defined.

FIG. 8 is a further mat configuration 56 exhibiting aspects alternate to that shown in FIG. 7 and in particular showing a more generally radial/linear defined arrangement of fluid pathways 58 in combination with concentric interconnected

6

passageways 60. A plurality of base supported and spaced apart/projecting portions 62 are provided, these each exhibiting a generally trapezium or trapezoidal shape and in order to create another uniquely configured and passageway supporting network for the associated lubricant.

FIG. 9 is a perspective end view 64 of a modified receiver bone end surface, and depicting a plurality of fluid filled pockets/cavities according to a variety of different configurations, this substituting directly for the intermediately supported mat of the several preceding variants. In particular, the pocket defined cavities may include rounded or arcuate shaped cavities, see at 66, as well as doughnut shaped cavities, at 68, all for the purpose of establishing a frictionless lubricated and wear resistant surface all across the inner recessed surface profile 70 for the defined joint.

FIG. 10 is cross sectional side view along line 10-10 of FIG. 9 and further showing, from another angle, the fluid retaining pockets of FIG. 9. In particular, and although the receiving, and recessed, pocket surface 70 of the bone 64 is illustrated in a less inwardly recessed pronounced fashion, it is understood that such a surface can also exhibit an inner/arcuately defined, and substantially spherical, configuration such as is shown in FIGS. 1 and 2.

Referencing finally FIGS. 11 and 12, perspective end facing and cross sectional side views are presented of another variation of receiver bone 72, with an associated (and again inwardly recessed) end surface 74 exhibiting alternatively configured and cross-shaped fluid retaining pockets 76. The configuration of the pockets 76 can be such as to improve localized concentration of lubricant, in cooperation with the sizing, spacing and placement of the pockets across the surface of the receiver bone to which it is affixed.

Having described my invention, other and additional preferred embodiments will become apparent to those skilled in the art to which it pertains, without deviating from the scope of the appended claims.

I claim:

1. An artificial joint associated with an implant, a pair of three dimensional and structurally extending bones including a male bone and a female bone, each defining a contoured and opposing end face, which collectively defines a joint location, said joint comprising:

a first softened plasticized layer adapted to being applied to a convex end face of the male bone;

a second softened plasticized layer adapted to being applied to an opposing and concave end face of the female bone and, upon seating the convex end face of the male bone, coacting in an articulating fashion;

a polymeric based mat exhibiting a selected length, width and thickness and which is flexibly secured upon a selected one of said convex or concave shaped plasticized layers, said mat filling a three dimensional space associated with the joint location between said first and second plasticized layers and so that an exposed surface of said mat articulates relative to the other selected one of said plasticized layers, said exposed surface of said mat having a plurality of projecting contact locations with said other selected plasticized layer, a network of intercommunicating and lubricant retaining channels extending around said projecting contact locations, said network of channels including a first plurality of radially outward extending passageways intersecting a second plurality of concentrically arranged passageways for receiving, supporting, and distributing the lubricant evenly across a surface area associated with said articulating layer in friction reducing fashion; and

a hardened plastic terminating in each of said first and second softened layers, a plurality of ridges formed with said mat defining contact locations for said other softened plastic layer associated with the other of the bones.

2. The invention as described in claim 1, said mat further comprising a first additive selected from at least one of a carbon and a graphite, and a second additive selected from at least one of a ceramic and a metal for providing said flexible and polymeric based mat with enhanced wear resistant properties.

3. The invention as described in claim 1, said bones each having a specified shape and size and establishing a joint selected from a group including at least one of upper/lower knee joint and an outer/inner ball and socket joint.

4. The invention as described in claim 1, said plasticized layer having a specified shape and size and further comprising an antimicrobial plastic.

* * * * *