



US008758439B2

(12) **United States Patent**
Linares

(10) **Patent No.:** **US 8,758,439 B2**
(45) **Date of Patent:** ***Jun. 24, 2014**

(54) **SPINE SUPPORT IMPLANT INCLUDING INTER VERTEBRAL INSERTABLE FLUID BALLASTABLE INSERT AND INTER-VERTEBRAL WEB RETAINING HARNESESSES**

(75) Inventor: **Miguel A. Linares**, Bloomfield Hills, MI (US)

(73) Assignee: **Linares Medical Devices, LLC**, Auburn Hills, MI (US)

(*) Notice: Subject to any disclaimer, the term of this patent is extended or adjusted under 35 U.S.C. 154(b) by 88 days.
This patent is subject to a terminal disclaimer.

(21) Appl. No.: **13/397,853**

(22) Filed: **Feb. 16, 2012**

(65) **Prior Publication Data**

US 2012/0150303 A1 Jun. 14, 2012

Related U.S. Application Data

(63) Continuation-in-part of application No. 12/273,067, filed on Nov. 18, 2008.

(60) Provisional application No. 60/988,921, filed on Nov. 19, 2007.

(51) **Int. Cl.**
A61F 2/44 (2006.01)

(52) **U.S. Cl.**
USPC **623/17.11**

(58) **Field of Classification Search**
USPC 606/246, 250-278; 623/17.11-17.16
See application file for complete search history.

(56) **References Cited**

U.S. PATENT DOCUMENTS

5,522,899 A	6/1996	Michelson
5,653,763 A	8/1997	Errico et al.
5,683,391 A	11/1997	Boyd
5,782,832 A	7/1998	Larsen et al.
6,001,130 A	12/1999	Bryan et al.
6,045,579 A	4/2000	Hochshuler et al.
6,228,085 B1	5/2001	Theken et al.
6,447,546 B1	9/2002	Bramlet et al.
6,626,904 B1	9/2003	Jammet et al.
6,626,909 B2	9/2003	Chin
6,641,614 B1	11/2003	Wagner et al.
6,645,207 B2	11/2003	Dixon et al.
6,736,850 B2	5/2004	Davis
6,936,071 B1	8/2005	Marnay et al.
7,201,775 B2	4/2007	Gorenssek et al.
7,276,082 B2	10/2007	Zdeblick et al.

(Continued)

FOREIGN PATENT DOCUMENTS

WO WO-2008011492 A2 1/2008

Primary Examiner — Mary Hoffman

Assistant Examiner — Michelle C Eckman

(74) *Attorney, Agent, or Firm* — Gifford, Krass, Sprinkle, Anderson & Citkowski, P.C.; Douglas J. McEvoy

(57) **ABSTRACT**

An implant support device associated with succeeding spinal vertebrae, including a harness exhibiting a plurality of legs, each extending from a rotatable bearing or suitable interconnecting support. Each of the legs terminates in an angled tang, this being engaged with a surface of a selected vertebrae. Additional features include undercut portions defined between the legs and arcuate/hemispherical mounting locations surrounding the bearing in individually rotatably permitting fashion. Inter-vertebral support cushions are also positioned between succeeding vertebrae, and can be incorporated with or provided separately from the web support harnesses.

7 Claims, 7 Drawing Sheets

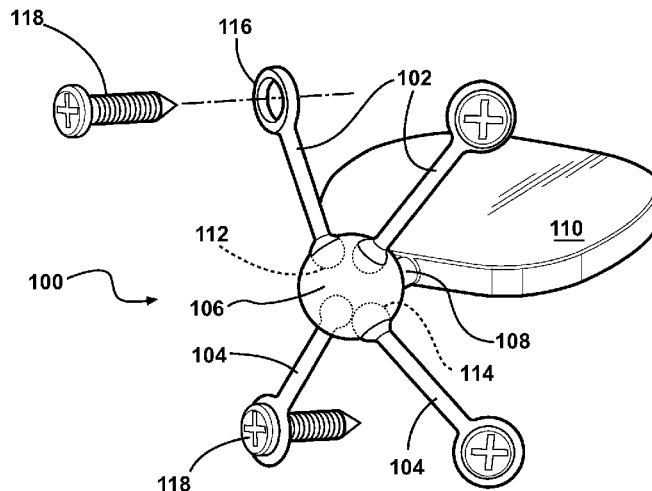

(56)

References Cited

U.S. PATENT DOCUMENTS

7,316,714	B2	1/2008	Gordon et al.	2005/0277930	A1	12/2005	Parsons
7,320,707	B2	1/2008	Zucherman et al.	2006/0009851	A1	1/2006	Collins et al.
7,344,564	B2	3/2008	Sweeney	2006/0036240	A1	2/2006	Colleran et al.
7,473,269	B1	1/2009	Hynes	2006/0084984	A1	4/2006	Kim
7,507,243	B2	3/2009	Lambrech et al.	2006/0085074	A1	4/2006	Raiszadeh
7,563,283	B2	7/2009	Kwak	2006/0149230	A1	7/2006	Kwak et al.
7,575,577	B2	8/2009	Boyd et al.	2006/0229609	A1*	10/2006	Wang 606/61
7,585,316	B2	9/2009	Trieu	2006/0235414	A1*	10/2006	Lim et al. 606/73
7,585,325	B2	9/2009	Schneid et al.	2006/0241601	A1*	10/2006	Trautwein et al. 606/61
7,604,654	B2	10/2009	Fallin et al.	2006/0241766	A1	10/2006	Felton et al.
7,655,045	B2	2/2010	Richelsoph	2006/0276898	A1	12/2006	Jackson
7,682,376	B2	3/2010	Trieu	2006/0282078	A1	12/2006	Labrom et al.
7,763,052	B2	7/2010	Jahng	2007/0005062	A1	1/2007	Lange et al.
7,766,966	B2	8/2010	Richelsoph	2007/0083199	A1	4/2007	Baccelli
7,776,069	B2	8/2010	Taylor	2007/0093829	A1	4/2007	Abdou
7,901,434	B2	3/2011	Drewry et al.	2007/0112428	A1	5/2007	Lancial
7,909,852	B2	3/2011	Boomer et al.	2007/0168036	A1	7/2007	Ainsworth et al.
2002/0022887	A1	2/2002	Huene	2007/0168039	A1	7/2007	Trieu
2002/0143329	A1	10/2002	Serhan et al.	2007/0185489	A1	8/2007	Abdou
2004/0015166	A1	1/2004	Gorek	2007/0213719	A1*	9/2007	Hudgins et al. 606/61
2004/0030398	A1	2/2004	Ferree	2007/0225813	A1	9/2007	Haines
2004/0082998	A1	4/2004	Shinomiya et al.	2007/0233089	A1*	10/2007	DiPoto et al. 606/61
2004/0210226	A1*	10/2004	Trieu 606/72	2007/0288011	A1*	12/2007	Logan 606/61
2005/0113927	A1	5/2005	Malek	2008/0021466	A1	1/2008	Shaddock et al.
2005/0131406	A1*	6/2005	Reiley et al. 606/61	2008/0039943	A1	2/2008	Le Couedic
2005/0216004	A1	9/2005	Schwab	2008/0114358	A1*	5/2008	Anderson et al. 606/64
2005/0216087	A1	9/2005	Zucherman et al.	2008/0183294	A1*	7/2008	Adl 623/17.16
2005/0245930	A1	11/2005	Timm et al.	2008/0269904	A1*	10/2008	Voorhies 623/17.16
2005/0256578	A1*	11/2005	Blatt et al. 623/17.15	2009/0112266	A1*	4/2009	Weng et al. 606/257
				2010/0222820	A1	9/2010	Trieu
				2011/0029084	A1	2/2011	Milbocker et al.
				2011/0224793	A1	9/2011	Fortin et al.

* cited by examiner

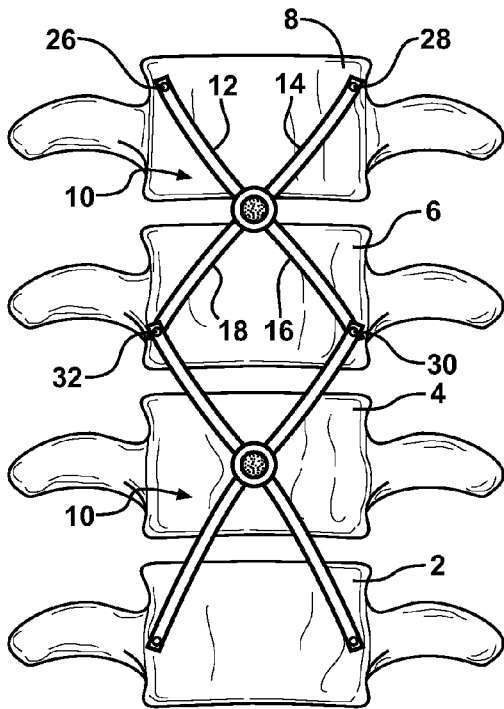

FIG. 1

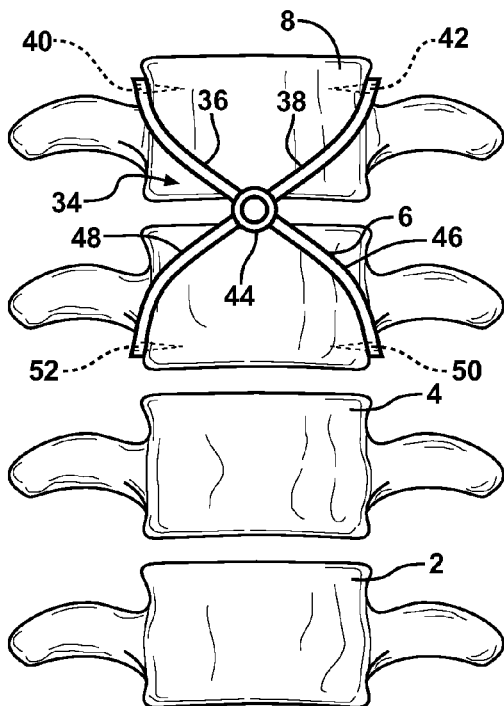
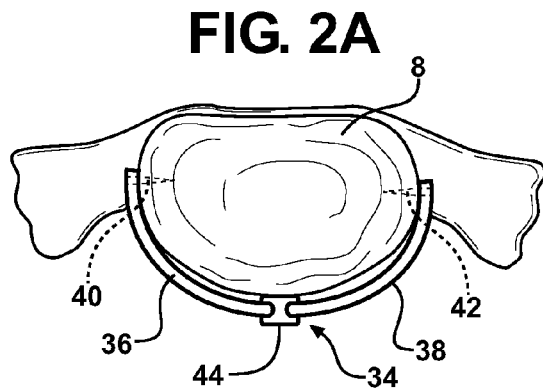

FIG. 2B

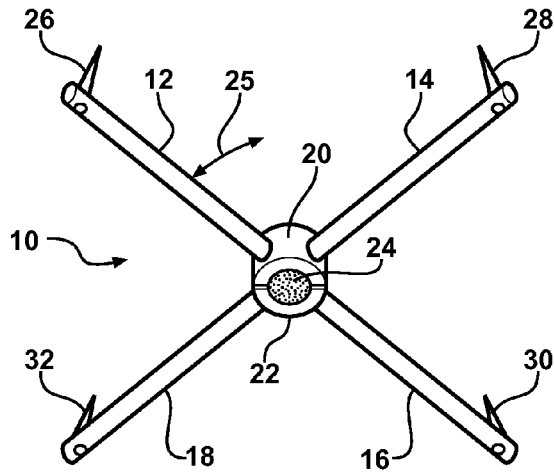

FIG. 3

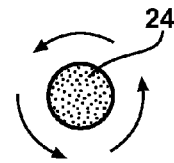

FIG. 3A

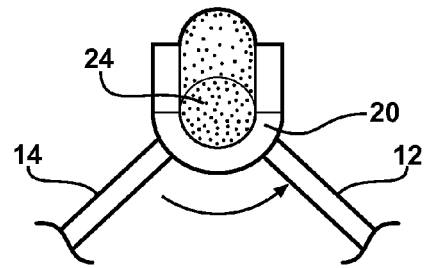

FIG. 3B

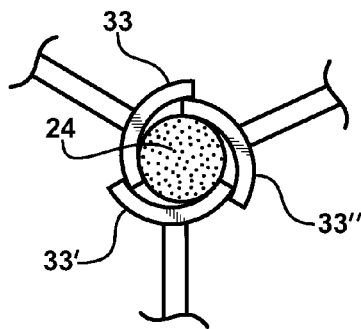

FIG. 3C

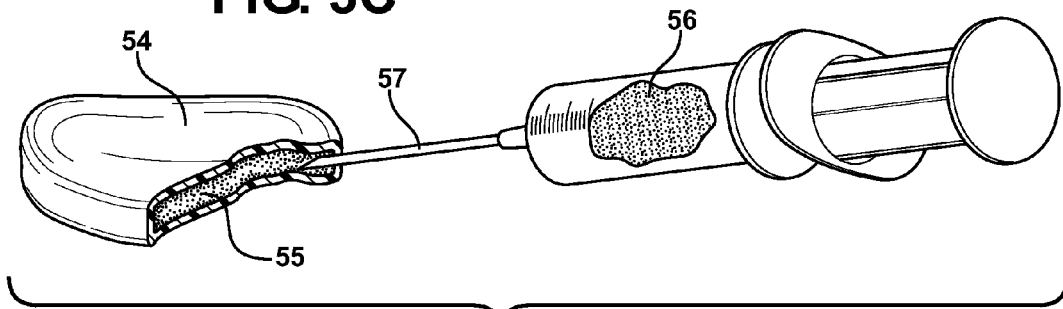

FIG. 4

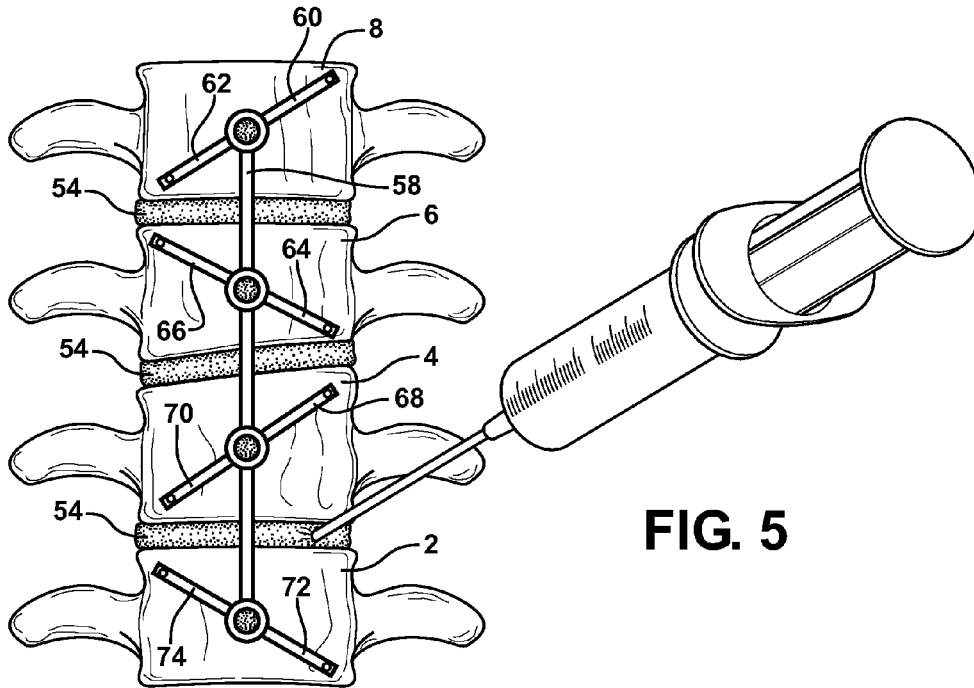

FIG. 5

FIG. 6

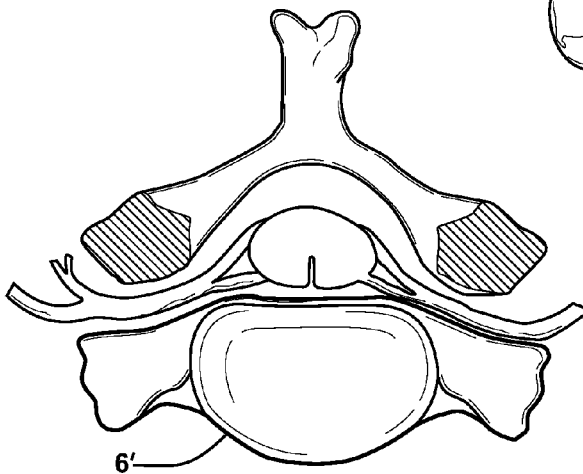
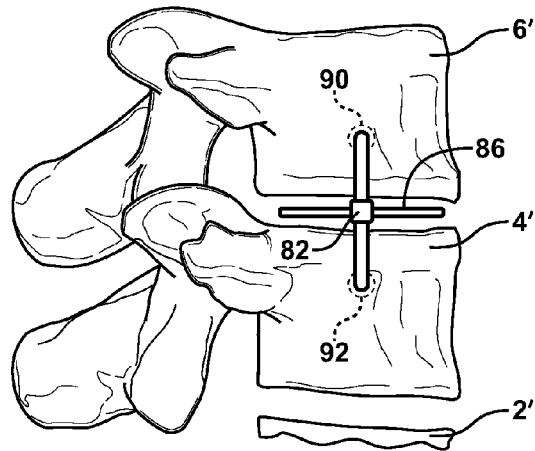
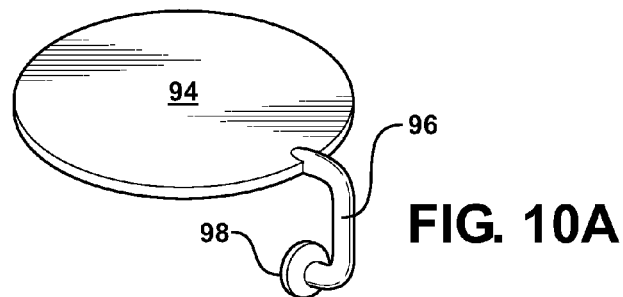
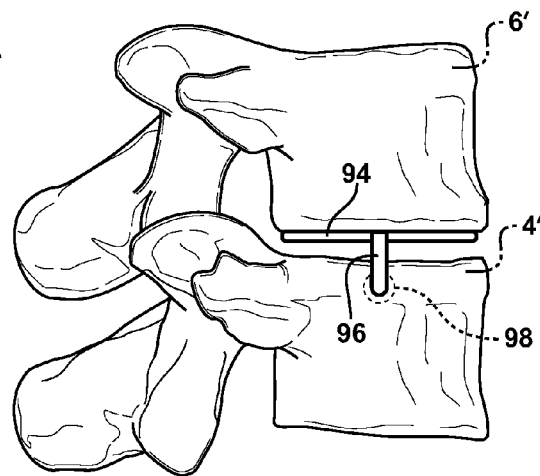
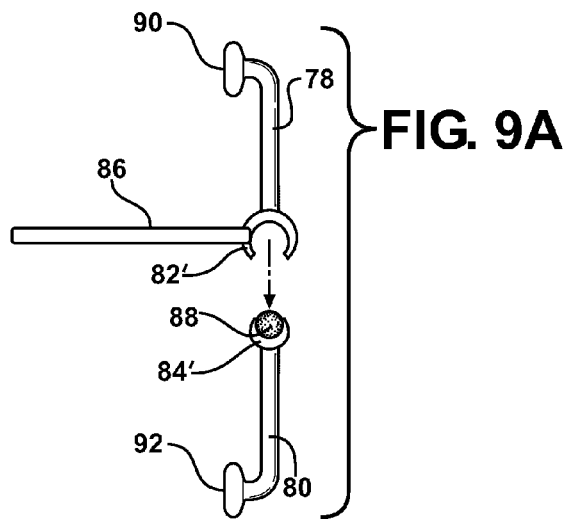
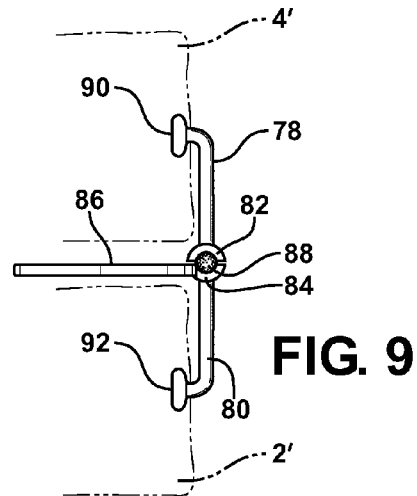
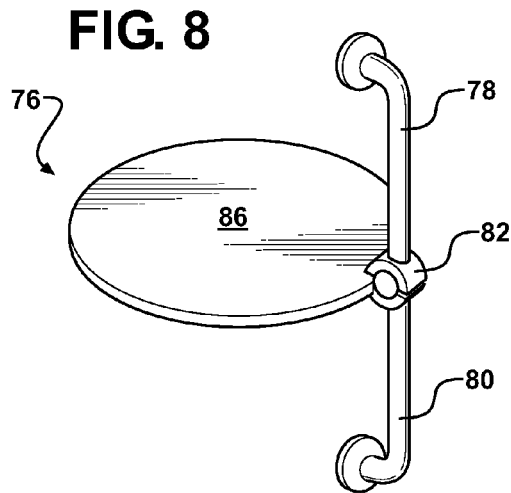

FIG. 7
PRIOR ART



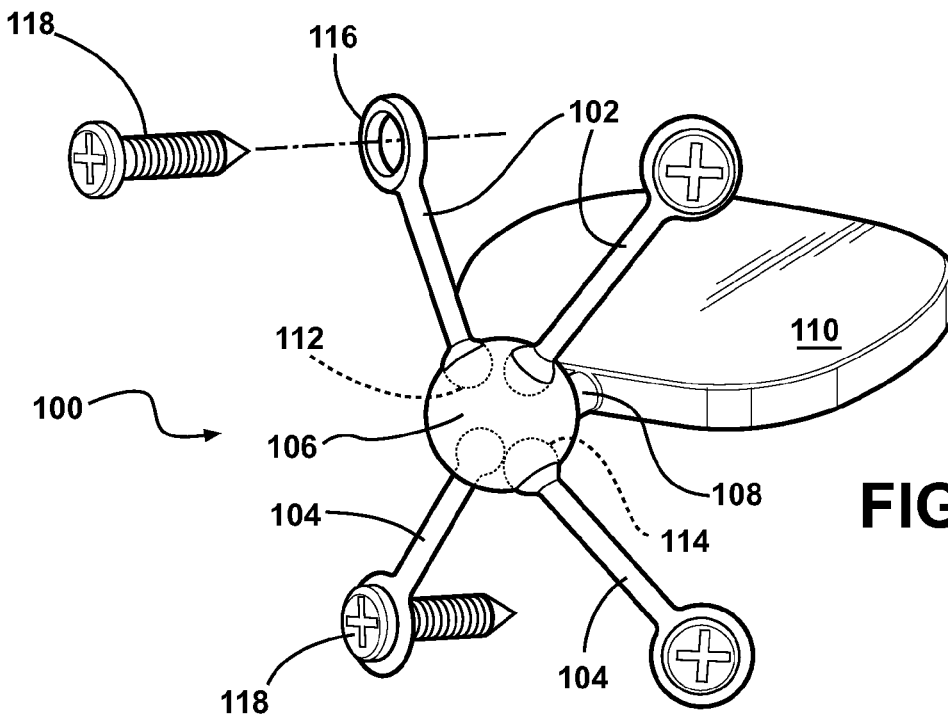

FIG. 11

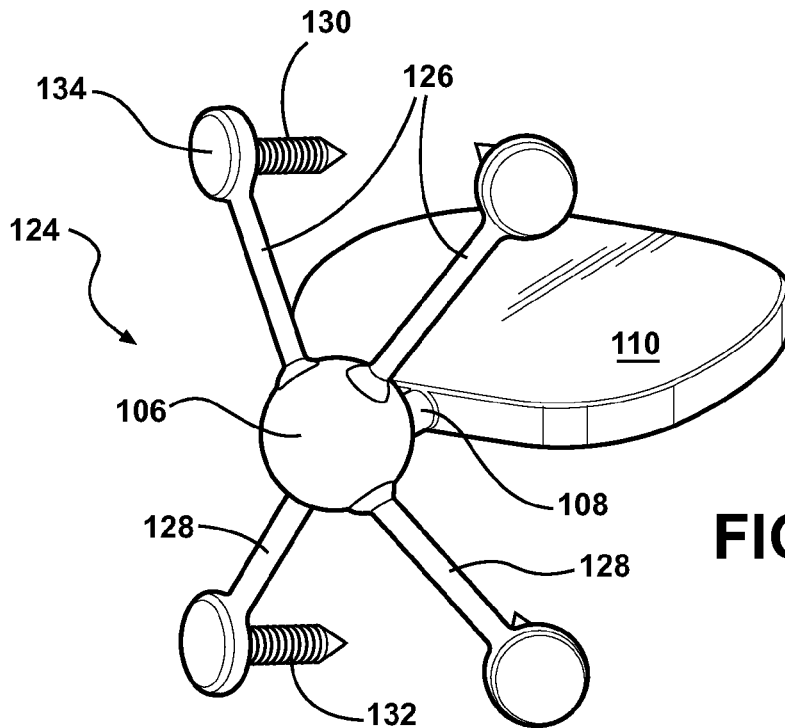
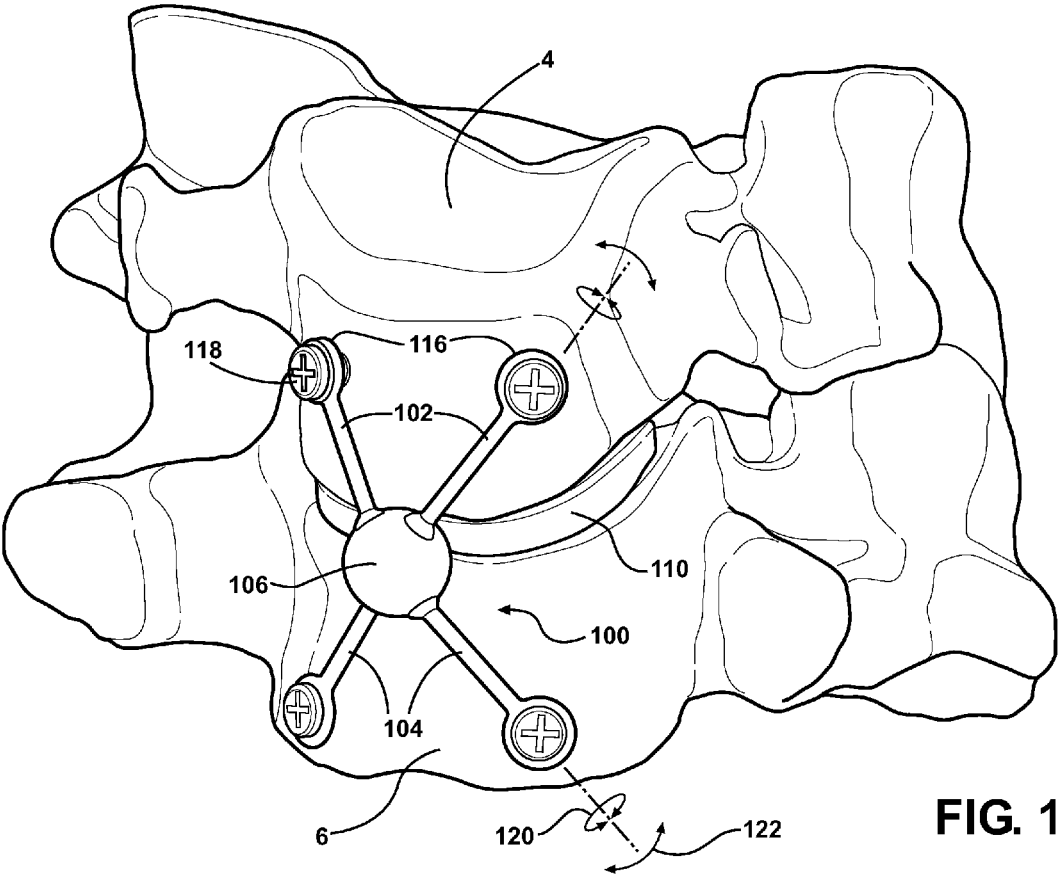

FIG. 13



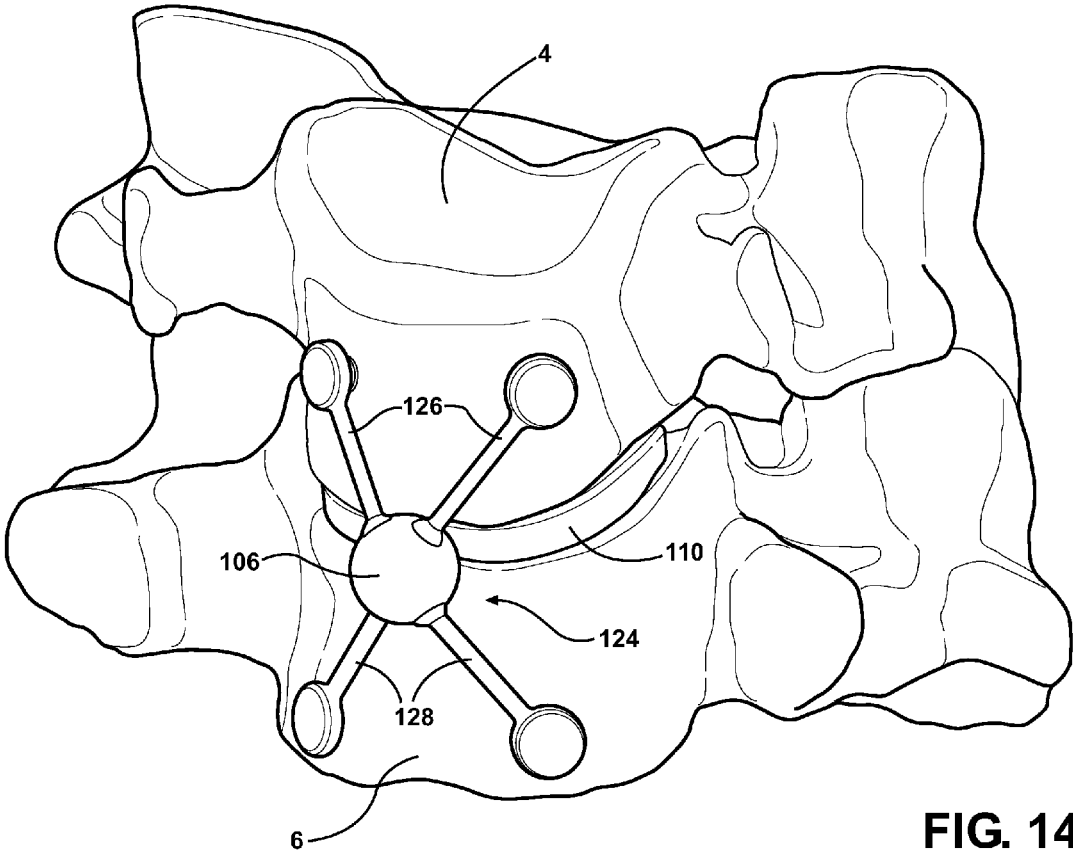

FIG. 14

1

**SPINE SUPPORT IMPLANT INCLUDING
INTER VERTEBRAL INSERTABLE FLUID
BALLASTABLE INSERT AND
INTER-VERTEBRAL WEB RETAINING
HARNESSES**

CROSS-REFERENCE TO RELATED
APPLICATIONS

This Application is a Continuation-in-part of application Ser No. 12/273,067 filed on Nov. 18, 2008, which in turn claims the benefit of U.S. Provisional Application 60/988,921 filed on Nov. 19, 2007.

FIELD OF THE INVENTION

The present invention teaches a improved applications of spinal support implants, these relating in particular to versions of web harness supports for use with succeeding vertebrae and which, in combination with selective cushioning implants or integrally defined and displaceably mounted disk portions formed with the web harnesses, operate to provide a degree of movement permitting support to a damaged spinal column, short of requiring the vertebrae be fused together. By virtue of avoiding the prior art necessity of fusing selected vertebrae within the spinal column, the remaining (non-fused) vertebrae are prevented from being overloaded, which will otherwise occur, and suffering premature damage.

BACKGROUND OF THE INVENTION

The prior art is well documented with varying examples of inter-vertebral positioning and supporting devices. The advantage in each instance is to fuse or immobilize the vertebrae, such as in response to injury or illness. Fusing or immobilizing inter-vertebral movement is often necessary in order to prevent ongoing discomfort or pain which can result from undesirable contact between misaligned or misshapen vertebrae, in particular when the spinal nerve column or its individual branches are affected.

Examples of known inter-vertebral stabilization devices are such as those set forth in US 2007/0093829 to Abdou and U.S. Pat. No. 6,645,207 to Dixon. Other insert or repair structures are also known, and which are positioned between opposing annular (or body) portions of succeeding vertebrae. One example of this is set forth in the disk repair structure Zucherman 2005/0216087. Additional examples include the artificial spinal fusion implants in Michelson, U.S. Pat. No. 5,522,899, as well as in U.S. Pat. No. 5,782,832, to Larsen. Additional examples include the spine stabilization systems of Gorek 2004/0015166 and Malek 2005/0113927 and the posterior stabilization system of Kwak 2006/0149230.

SUMMARY OF THE INVENTION

The present invention discloses a spinal support implant for positionally securing succeeding vertebrae associated with a spinal column. Each of the preferred variants includes one or more web retaining harnesses, each of which exhibits a plurality of hardened plastic legs extending from central and hemi-spherical mounting locations. These hemispherical location include such as overlapping portions surrounding a central bearing in secured and rotatively permissive fashion.

The legs each include, at remotely extending ends, such as tangs/detents that securely mount to such as undercut locations in the individual vertebrae. In this fashion, the web harness generally and positionally immobilizes the succes-

2

sive spinal vertebrae to which it is attached, and while permitting a minor degree of misalignment and movement, such as is common in normal spinal activity, this again being prevented by such conventional alternate procedures as spinal fusion utilizing anchoring screws and plates.

An inter-vertebral support cushion can be provided separately or in integral combination with the web-retaining harness and which defines an additional component of the present invention which can be pre-positioned between succeeding vertebrae. In one variant, and following being pre-positioned in location (such as between opposing body or annular facing surfaces of succeeding disks) the bladder configured cushion can be selectively injection pressurized with a fluid, this in order to establish a given bias pressure. Another version of the present inventions combines the web support harnesses and inter-vertebral support cushions into a single article, which again features the hardened plastic legs extending from central and hemi-spherical mounting locations integrally formed with an edge location of the disk portion surrounding a central bearing in secured and rotatively permissive fashion, the legs again including tangs/detents that securely mount to such as undercut locations in the individual vertebrae.

An additional variant depicts a spherical support extending from a side edge location of an inter-vertebral inserted disk or cushioning member. A plurality of individual and elongated members, such as depicted in upper and lower pairs, are provided, each of which including a mini-spherical shaped lower end which is seated within a mating and substantially spherical shaped communicating socket interior defined in the spherical support.

Opposite remote extending ends of the elongated members are anchored in any suitable fashion to surface locations of the vertebrae. In this fashion, the vertebrae are permitted a degree of limited movement by virtue of the range of eccentric pivoting motion of the elongate members about their mini-spherical ends seated within the spherical support defined sockets.

BRIEF DESCRIPTION OF THE DRAWINGS

Reference will now be made to the attached drawings, when read in combination with the following detailed description, wherein like reference numerals refer to like parts throughout the several views, and in which:

FIG. 1 is a plan view illustration of one arrangement of a web retaining harness associated with a plurality of vertebrae forming a part of a spinal column according to an embodiment of the present inventions and for controllably and displacably supporting successive vertebrae;

FIG. 2A is a top view of a further configuration of web support harness according to the present inventions;

FIG. 2B is a plan view similar to FIG. 1 of the harness configuration shown in FIG. 2A, and illustrating peripheral engagement location of the of the mounting detents associated with the harness;

FIG. 3 is an illustration of a selected support harness and illustrating features such as hardened plastic legs extending from central and hemi-spherical mounting locations surrounding a central bearing in secured and rotatively permissive fashion, and including tangs/detents that securely mount to such as undercut locations in the individual vertebrae;

FIG. 3A is a partial view of a selected and inner most located bearing;

FIG. 3B is a further partial view illustrating a selected bearing and partial overlapping annulus contact associated with a given engagement leg;

3

FIG. 3C is a yet further partial view and illustrating a multiple overlapping relationship established by a plurality of three leg supporting annulus and bearing surface contact portions;

FIG. 4 is an illustration of an inter-vertebral support cushions defining a component of the present inventions and which is selectively injection pressurized with a suitable fluid medium in the manner illustrated;

FIG. 5 is an illustration similar to FIG. 1, and showing a further example of combination inter-vertebral web support harnesses and cushions;

FIG. 6 is a side plan view of a further configuration of support column with combination support disc retaining web harness according to another embodiment of the present inventions;

FIG. 7 is a top view of a vertebrae such as is also shown in FIG. 6 and such as is known in the Prior Art;

FIG. 8 is a perspective view of the combination disk and retaining web support harness according to the further preferred embodiment of FIG. 7;

FIG. 9 is a side plan view of the combination disk and harness of FIG. 8 and further showing the features of the hardened plastic legs extending from central and hemi-spherical mounting locations integrally formed with an edge location of the disk portion and surrounding a central bearing in secured and rotatively permissive fashion, the legs again including tangs/detents that securely mount to such as undercut locations in the individual vertebrae;

FIG. 9A is an exploded view of one configuration of leg and rotatable bearing as also shown in FIG. 9;

FIG. 10 is an illustration of an alternate mounting configuration of an inter-vertebral support disk;

FIG. 10A is a further perspective illustration of the variant shown in FIG. 10;

FIG. 11 is a perspective view of a further variant of retaining harness with eccentrically pivotally supported elongated members extending in upper and lower individually paired fashion from a spherical support extending from a side edge location of an inter-vertebral inserted disk or cushioning member;

FIG. 12 is an environmental depiction of the retaining harness of FIG. 11 installed between succeeding vertebrae;

FIG. 13 is a perspective view similar to FIG. 11 of a related variant of retaining harness and depicting integrally formed engagement screws extending from remote extending ends of the upper and lower pairs of the pivotally eccentrically supported and elongated extending members; and

FIG. 14 is an environmental depiction of the retaining harness of FIG. 13 installed between succeeding vertebrae.

DETAILED DESCRIPTION OF THE PREFERRED EMBODIMENTS

FIG. 1 is an illustration of a first arrangement of a web retaining harness 10 for controllably and displacingly supporting successive vertebrae, and as are shown at 2, 4, 6 and 8, forming a part of a spinal column. As previously discussed, the several variants of vertebral support implants, as disclosed herein, operate to provide a degree of movement permitting support to a damaged spinal column, and short of requiring the vertebrae be fused together as is conventionally performed in an attempt to address many spinal injuries, but which typically result in the patient experiencing significant losses in spinal mobility.

As is also described in reference to FIGS. 3-3C, the web support harness is illustrated as a pair of identically configured harnesses 10, typically each including hardened plastic

4

legs, see at 12, 14, 16 and 18. The legs each extend from central and hemi-spherical mounting locations, see at 20 and 22 in FIG. 3, these in turn surrounding a central bearing 24 in secured and rotatively permissive fashion.

While not limited to any specific material composition, the legs 12-18 can exhibit a composite plastic with sanitary or antibiotic properties and can further establish a desired degree of flex (or bend) so as to provide considerable positional engagement of the associated vertebrae, and while still providing for any incrementally (or minor) desired degree of movement between the vertebrae. In this fashion, the vertebrae are positionally immobilized to the degree desired, while at the same time the patient may still be provided with some minor degree of residual movement or flexibility, this consistent with the material aspects of the harness leg construction.

As shown in FIG. 3, one or more of the pairs of legs (e.g. see as again shown at 12 & 14, as well as at 16 & 18) can extend from each of first 20 and second 22 hemi-spherical (or arcuate) mounting locations, it being understood that the overlapping mounting locations are further capable of being constructed according to other shapes and configurations, and such that the legs 12-18 can exhibit respective degrees of flexibility, both individually and vis-à-vis one another. In this fashion, any degree of permissible rotation of the arcuate portions (e.g. hemi-spherical) 20 and 22 are transferred to the individual and integrally extending pairs 12 & 14 and 16 & 18 of legs. Each of the legs 12-18 further includes tangs (or prong shaped detents), see as respectively shown at 26, 28, 30 and 32 in FIG. 3, these being integrally formed at the outboard ends of the associated legs and which securely mount to such as drilled undercut locations formed in each of the individual vertebrae 2, 4, 6, and 8.

Although not illustrated, it is also envisioned that alternate fasteners can be employed for mounting the extending ends of the web harness legs to the associated vertebrae at locations which will promote optimal inter-vertebral stability and while allowing the vertebrae the possibility of exhibiting minor incremental degrees of flex or bend. In this fashion, any significant misalignment between vertebrae is prevented, and such as which could otherwise entail the undesirable incidence of pinching of the spinal nerve column (see as shown in the Prior Art illustration of FIG. 7 as associated with selected spinal vertebrae 6').

As further again shown at 24 in FIG. 3A, a partial view of a selected and inner most located bearing (see also FIGS. 1 and 3) is illustrated and which can include such as heavy duty nylon or other suitable material construction. As previously described, the first 20 and second 22 hemi-spherical (or arcuate) mounting locations are formed in mutually contacting and edge overlapping fashion, these encasing the centrally positioned bearing 24 and so that the bearing facilitates a desired degree of "give" or rotational support (see arrow 25 in FIG. 3 in relation to selected leg 12). It is also envisioned that the legs illustrated herein can be attached to such as undercut portions associated with the bearing mounting locations and in order to provide an alternate mounting variant.

FIG. 3B is a further partial view (with selected contact portion 22 removed) and illustrating bearing 24 and overlapping contact portion 20, from which extend each of the plurality of legs 12-18. It is also understood that the individual and arcuate shaped contact portions (e.g. again at 20 and 22) can exhibit any relative shape, as well as configuration for interconnecting in relative rotatable freedom about the bearing 24, the purpose for which being to impart a desired degree of rotational give or bend to the individual legs.

FIG. 3C is a yet further partial view and illustrating multiple and mutually overlapping edges established by a plural-

5

ity of three leg supporting annulus and bearing surface contact portions, see at **33**, **33'** and **33''**, these surrounding the central bearing **24** As shown in FIG. **3c**, individual extending legs (illustrated in reduced length) extend from the individual overlapping and bearing surface contact portions, it being understood that any plurality of legs as well as any number of individual bearing surface supported and overlapping contact portions, can be provided and which establish any desired degree of inter-rotation, bend or give to the individual legs.

Referring now to FIG. **2A**, a top view of a further configuration of web support harness, see at **34**, and specifically illustrating the feature of the associated legs **36** and **38** angled in order that the end defined tangs, at **40** and **42**, are mounted to substantially peripheral (outer) most defined locations associated with the selected vertebrae **8**. The illustration of FIG. **2A** further evidences the degree of flexibility (or bend) which is afforded the individual legs and in order to conformingly apply about the exterior periphery of the associated vertebrae. Referencing FIG. **2B**, the peripheral location of the upper most extending pair of legs **36** & **38** and associated mounting detents **40** & **42** is again shown associated with the harness **34** and in contrast to the mounting arrangement of FIG. **1**.

Consistent with that previously shown and described in reference to FIGS. **3-3C**, the construction of each harness again includes a central bearing, about which is supported one or more rotatably permissive contact locations, e.g. at **44**. As further shown in FIG. **2B**, the harness **34** includes a second (lower) pair of legs **46** and **48** with associated detents **50** and **52** and which likewise engage peripheral most defined locations associated with the succeeding vertebrae **6**. The illustrations of FIGS. **1** and **2B** are intended to demonstrate the range of possible mounting variations which are possible with the web support harness, and in particular the ability of the various extending legs to engage any suitable vertebral location, not limited to a peripheral edge or specified height location.

Referencing now FIG. **4**, an illustration is shown at **54** of an inter-vertebral support cushion, this defining a component which is capable of being used in combination with the web support harnesses **10**. As shown, the cushion **54** is constructed of a flexible and fluid retaining (as well as sanitary) plastic exhibiting an open interior (see as shown at **55** in cutaway). A syringe **56** is provided and includes a projecting needle **57** which allows for a volume of fluid contained within the syringe cylinder to be injected into the support cushion **54**.

The construction and consistency of the cushion (or bag) **54** is such that it is capable of being pre-positioned between succeeding vertebrae, as shown in FIG. **5**, following which it is selectively injection pressurized in the manner illustrated. FIG. **5** additionally illustrates an example of a combination of inter-vertebral web support harnesses and cushions **54**. The web support harness illustrated in FIG. **5** differs from that previously described, and includes in the illustrated embodiment a lengthwise extending support, this shown by stem **58** extending in overlapping fashion over any number of successively positioned vertebrae, and from which extend pairs of legs **60** & **62**, **64** & **66**, **68** & **70**, and **72** & **74**. Each of the individual pairs of legs extending in angular offset from the lengthwise (inter-vertebral) extending support **58**.

The individual pairs of legs in FIG. **5** further extend in diagonally and alternating offsetting fashion, and such that respective end defined tangs/detents associated with each pair of legs secure to upper and lower opposite end locations of a selected vertebrae **2-8**, thereby position ally supporting the individual vertebrae via the lengthwise extending and central supporting stem **58**. It is also envisioned that adhesives can be

6

employed for securing the lengthwise and diagonally offsetting legs. Additionally, the fluid injectable cushions **54**, upon being filled, are designed in one variant to cure and set, this to establish minimal/incremental degrees of permitted movement relative to opposing annulus surfaces of the central body portions of the individual vertebrae (see again FIG. **5**), and the cushions are further prevented from dislodging from between the vertebrae by virtue of the exterior surface mounted web harnesses, and which may be provided along each of opposite exterior sides of a pair of interconnected vertebrae.

Referring now to FIGS. **6** and **8**, both perspective and side environmental plan views are shown of a further configuration of support column with combination support disc and retaining web harness **76**, according to another embodiment of the present inventions. In particular, and is most clearly illustrated in each of FIG. **8** and the assembly views of FIGS. **9** and **9A**, the combination disk and retaining web support harness includes the features of hardened plastic legs, see as shown at **78** and **80**, these extending from central and hemispherical shaped mounting portions, at **82** and **84**.

As further shown, an inter-vertebral disk inserting portion **86**, such as also exhibiting a hardened surface, is integrally formed in extending fashion with an edge location of a selected mounting portion (in this instance **82**). As shown in each of the side (FIG. **6**) and ninety degree rotated (FIG. **9**) views, the disk inserting portion **86** is positioned in the space established between a pair of opposing and succeeding annular body surfaces of selected vertebrae, subsequent to which the legs **78** and **80** are secured to surface locations of the succeeding vertebrae.

The variation of FIG. **9A** differs somewhat from that shown in FIGS. **8** and **9**, and by which the mounting portions are modified, see as shown at **82'** and **84'**, such that the first portion **82'** exhibits an enlarged inner arcuate recess, into which is resistively and snap-fit engaged the second (smaller dimensioned) portion **84'**. The bearing is again shown at **88** and is sized so that it is supported upon the inner recess of the second mounting portion **84'** and, upon snap fitting the first larger mounting portion **82'** over the bearing **88** and second smaller portion **84'**, establishes a desired degree of movement between the legs **78** and **80**.

The extending legs **78** and **80** each exhibit end-configured detents **90** and **92** which secure to such as again undercut locations (not shown) formed along the sides of the vertebrae. Accordingly, a modified range of motion is permitted between the legs **78** and **80**, by virtue of the snap-fit arrangement established by the hemi-spherical portions **82** and **84** (or at **82'** and **84'** in FIG. **9A**) about the spherical shaped bearing **88** supported therebetween. It is further understood that the combination disc support and retaining harness **76** can also be provided, either additionally or alternatively, to any of the harness or interior support cushion arrangements described herein.

FIGS. **10** and **10A** illustrate a yet further alternate mounting configuration in which is provided an inter-vertebral support disk, see at **94**. As opposed to the pair of support legs in the variant of FIG. **8**, a single mounting location is provided by extending and inwardly angled leg **96** (this being illustrated substantially "L" shaped relative to the insertable disk portion **94**) and which terminates in a single tang/detent mounting location **98**. The purpose of the support disk **94** variant is, in part, to illustrate one of a number of potentially different configurations which can be employed in installing a combination central disc support and exterior surface engaging harness between succeeding spinal vertebrae.

Referring now to FIG. **11**, a perspective view is generally shown at **100** of a further variant of retaining harness with

eccentrically pivotally supported elongated members, such as depicted in paired upper **102** and lower **104** extending fashion from a spherical support **106**. The spherical support **106** extends, via a connecting projection or finger **108**, from an exposed side edge location of an inter-vertebral inserted disk **110** or other suitable supporting and/or cushioning member, following implantation of the disk as depicted in FIG. **12**. For purposes of description, the disk **110** can also be reconfigured as any of the previously described cushioning **54** in FIG. **4** or the hardened disks as exemplified at **86** in FIG. **8**.

FIG. **12** is an environmental depiction of the retaining harness **100** of FIG. **11** installed between succeeding vertebrae. Of note, the upper **102** and lower **104** pairs of individual and elongated members (such as also termed as extending arms or leg) are each provided at first or inner pivotally connecting ends with a mini-spherical shaped portions (see in phantom at **112** and **114** in FIG. **11**), these being seated within mating and substantially spherical shaped communicating socket interior locations defined at three dimensional surface offset locations in the spherical support **106** in both an eccentric and bearing-like supported fashion as will be further described.

Opposite remote extending ends of the elongated members **102** and **104** are configured with integrally defined eyelet locations, see for example best shown at **116** associated with selected upper extending elongated member **102** in FIG. **11**, such that bone screws **118** are inserted through the open interior of each end configured eyelet **116** with the heads of the screws abutting against the sides of the eyelets in order to retain the harness upon anchoring of the screws within the indicated vertebrae mounting locations in FIG. **12**. In this fashion, and upon mounting the harness **100** in the manner shown in FIG. **12**, the vertebrae **4** and **6** are permitted a degree of inter-movement by virtue of eccentric (both rotational and pivotal) motion of the elongate members about their mini-spherical ends seated within the spherical support defined sockets, see both rotational **120** and pivotal **122** directional arrows. The effect of this mounting arrangement is that the elongated members each establish a desired three dimensional bearing relationship with the spherical support **106**, this providing the desired and limited degree of inter-movement between the succeeding vertebrae **4** and **6**.

FIG. **13** is a perspective view similar to FIG. **11** of a related variant **124** of retaining harness, differing from the example of FIG. **11** only in the configuration of upper **126** and lower **128** pairs of elongated members, each of which depict integral screws **130** and **132** respectively extending from flattened end supports **134** and **136**. As with the previously described embodiment **100** of retaining harness, and referring to FIG. **14**, the manner of implanting the harness **124** relative to a pair of vertebrae **4** and **6** is illustrated and by which the desired degree of eccentric (i.e. both rotational and limiting pivotal) motion of the upper and lower pairs of elongated members relative to the socket retaining interiors of the spherical support **106** is established such as which provides increased spinal flexibility while safeguarding against pinching of the associated spinal nerve column and individual vertebral branches. In this fashion, an ideal balance is struck between providing some degree of flexibility (as opposed to fixed or immovable anchoring of the vertebrae through conventional plates and screws), without the undue risk of the pain associated with nerve pinching.

Additional variants to those depicted in FIGS. **11-14** include reconfiguring the elongated members both in number as well as shape and material consistency and properties. The

screw mounting ends can also be reconfigured to reflect undercut mounting relationships with the vertebral bone locations.

Other changes can include the inter vertebral support inserting disks **110** being reconfigured to accommodate differing insertion applications as well as in order to provide different dynamic operational specifications. The harnesses may further be redesigned in order to anchor, in likewise eccentric and limited inter-moveable fashion, any greater number of vertebrae beyond the two illustrated in the examples depicted herein.

Having described my invention, other and additional preferred embodiments will become apparent to those skilled in the art to which it pertains, and without deviating from the scope of the appended claims:

I claim:

1. An implant support device adapted for use with succeeding spinal vertebrae, said device comprising:
 - a flattened disk having a specified shape and size and which is adapted to being inserted between opposing surfaces of the succeeding vertebrae;
 - a first pair of legs extending from a three dimensional portion integrally formed along an edge of said disk, said first pair of legs each exhibiting multi-axial flexibility in order to conform in extending fashion over a contoured surface of a first of the succeeding vertebrae, said legs each terminating in a fastener adapted to engaging a location associated with the first vertebra;
 - a second pair of legs extending from said three dimensional portion in directions opposite said first pair of legs, said second pair of legs each exhibiting multi-axial flexibility in order to conform in extending fashion over a contoured surface of a second of the succeeding vertebrae, said second legs each terminating in a fastener adapted to engaging a location associated with the second vertebra;
 - each of said first and second pairs of legs further having a spherical shaped end opposite said fastener end, said spherical shaped ends resistively fitting within a spherical shaped socket defined in communicating fashion with surface locations of said three dimensional portion, said spherical ends facilitating motion between the vertebrae concurrent with cushioning the inner opposing surfaces of the first and second vertebrae.
2. The device as described in claim **1**, further comprising a finger projection for spacing said three dimensional portion from said edge of said disk.
3. The device as described in claim **1**, said fasteners further comprising integrally defined eyelet locations adapted to receive bone screws inserted through an open interior of each end configured eyelet such that enlarged heads of the screws abut against sides of said eyelets upon being adapted to anchoring within the vertebral bone locations.
4. The device as described in claim **1**, said fasteners further comprising integrally formed end supported and bone engaging screws for anchoring within vertebra bone locations.
5. The device as described in claim **1**, said disk further comprising an inter-vertebra cushion.
6. The device as described in claim **5**, further comprising said cushion being constructed of a flexible and fluid injectable plastic and, upon being pre-positioned between succeeding vertebra, being injected with an internally ballasting and curable/settable composition for establishing a degree of supported and incremental movement between the vertebrae.

7. The device as described in claim 1, said three dimensional portion further comprising a spherical shape within which said spherical shaped individual pockets are formed.

* * * * *