



US 20140330380A1

(19) **United States**

(12) **Patent Application Publication**
LINARES

(10) **Pub. No.: US 2014/0330380 A1**

(43) **Pub. Date: Nov. 6, 2014**

(54) **CLAMPING ASSEMBLIES FOR SECURING LIGAMENTS TO A BONE**

(52) **U.S. Cl.**

CPC *A61F 2/0811* (2013.01); *A61F 2002/0852* (2013.01); *A61F 2002/0864* (2013.01); *A61F 2002/087* (2013.01); *A61F 2002/0882* (2013.01); *A61F 2002/0888* (2013.01); *A61F 2220/0008* (2013.01); *A61F 2002/0829* (2013.01); *A61F 2002/0835* (2013.01)

(71) Applicant: **Linares Medical Devices, LLC**, Auburn Hills, MI (US)

(72) Inventor: **Miguel A. LINARES**, Bloomfield Hills, MI (US)

USPC **623/13.14**

(73) Assignee: **Linares Medical Devices, LLC**

(21) Appl. No.: **14/331,830**

(57)

ABSTRACT

(22) Filed: **Jul. 15, 2014**

Related U.S. Application Data

(62) Division of application No. 12/797,156, filed on Jun. 9, 2010, now Pat. No. 8,801,784.

(60) Provisional application No. 61/186,215, filed on Jun. 11, 2009.

A clamp assembly for engaging a bunched end of ligaments to a bone mounting location, the assembly including pair of split body portions, each including an enlarged head adapted to being mounted within a location of the bone, the split body portions each further including an extending stem portion. Each of the body portions further exhibits opposing inner mating surfaces establishing a centrally located and length extending parting line. Pluralities of spaced apart engaging tabs extend between the enlarged head and stem portions for engaging around the bunched ligaments in compressive and retaining fashion.

Publication Classification

(51) **Int. Cl.**

A61F 2/08

(2006.01)

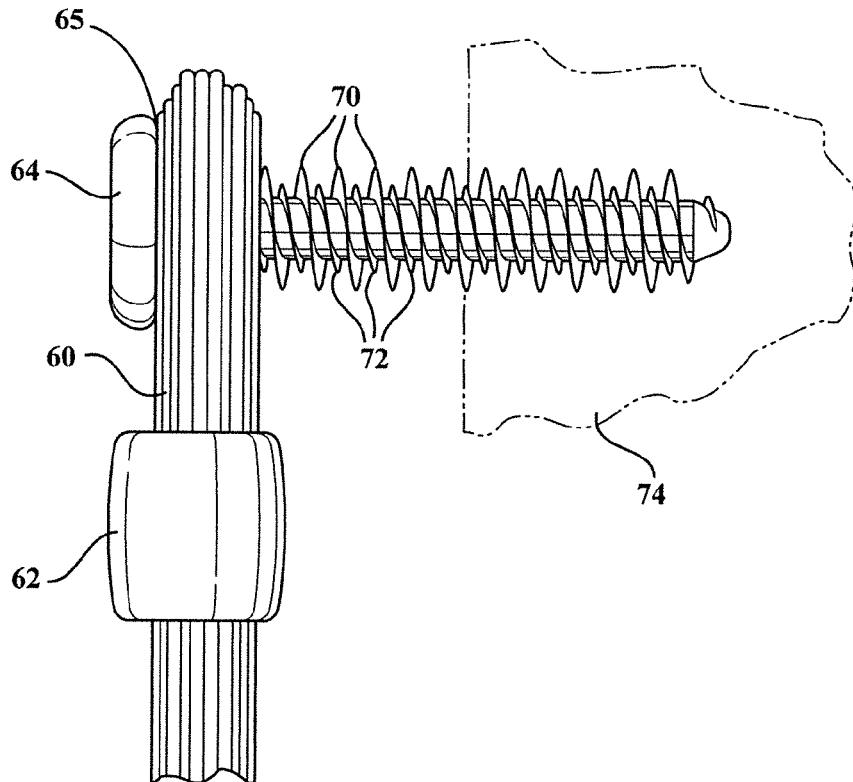

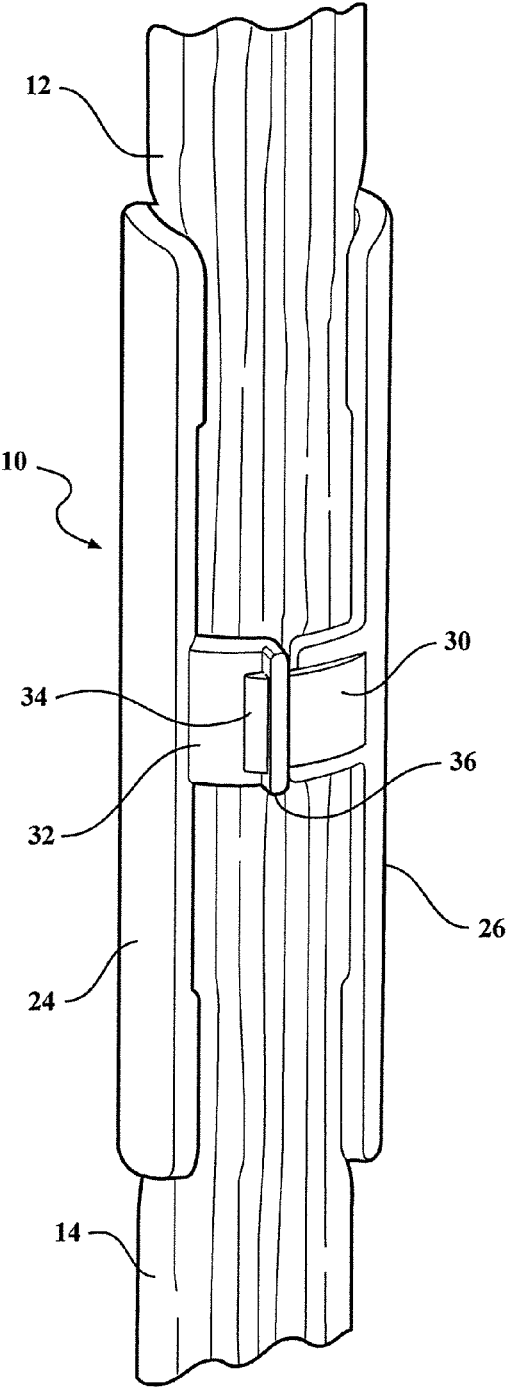

FIG. 1

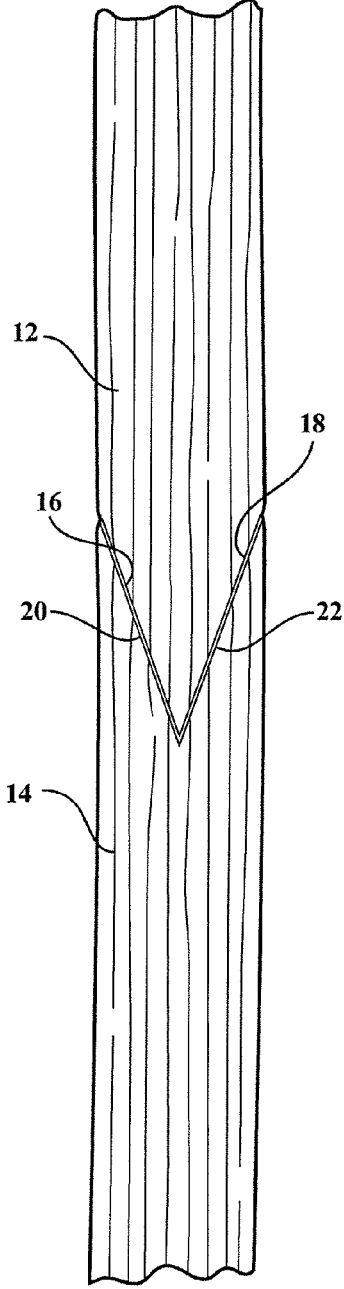

FIG. 2

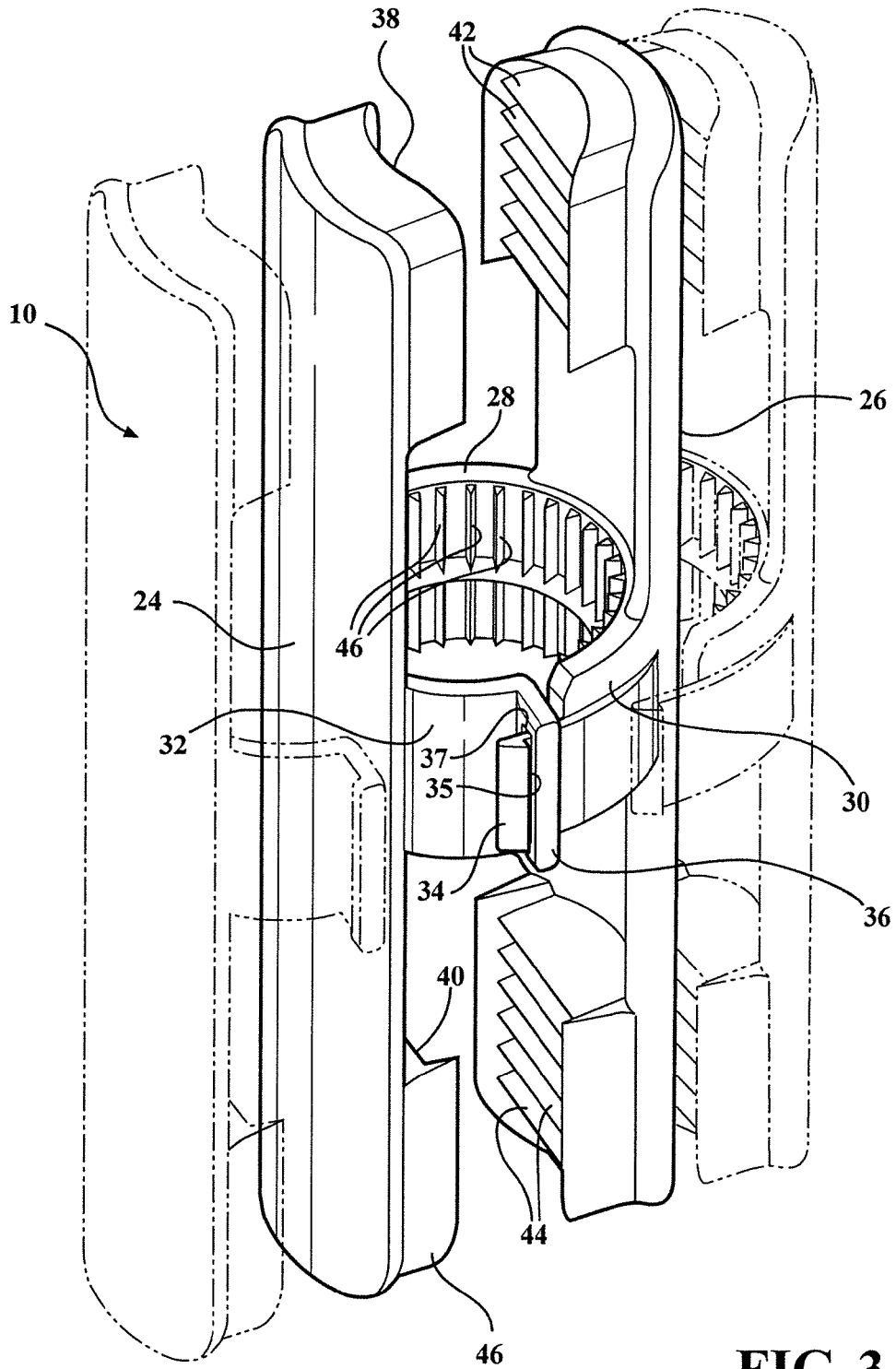

FIG. 3

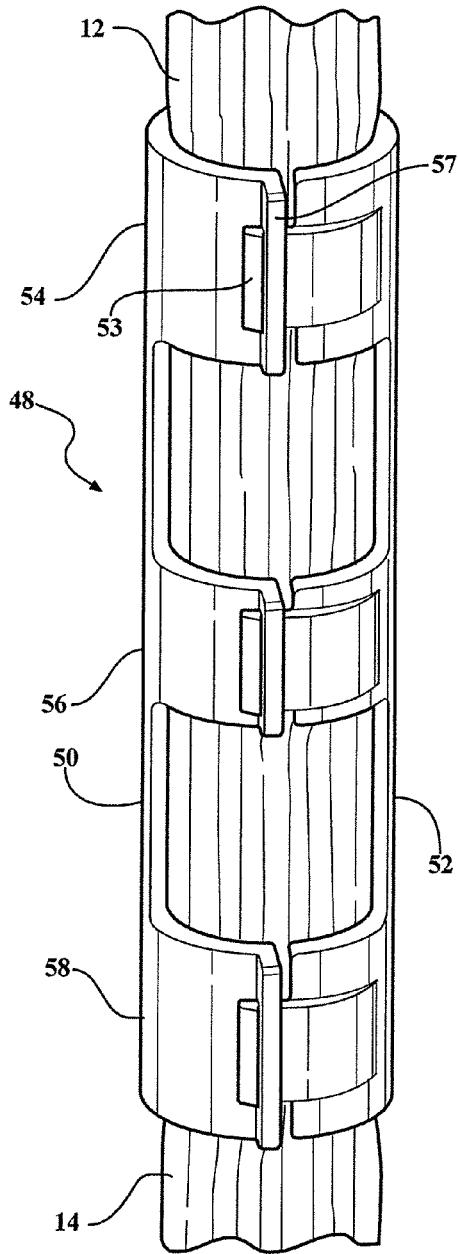

FIG. 4

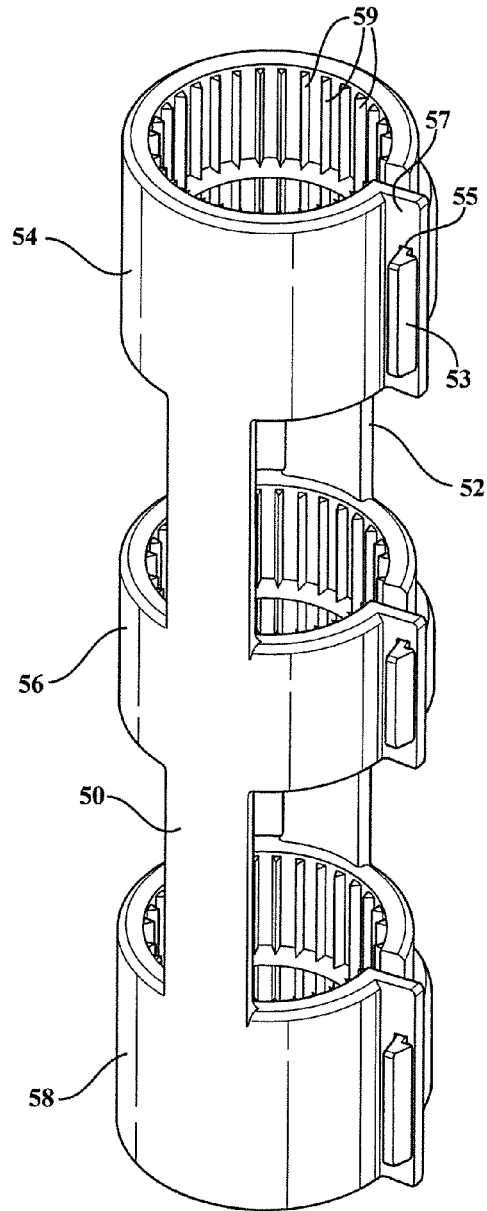
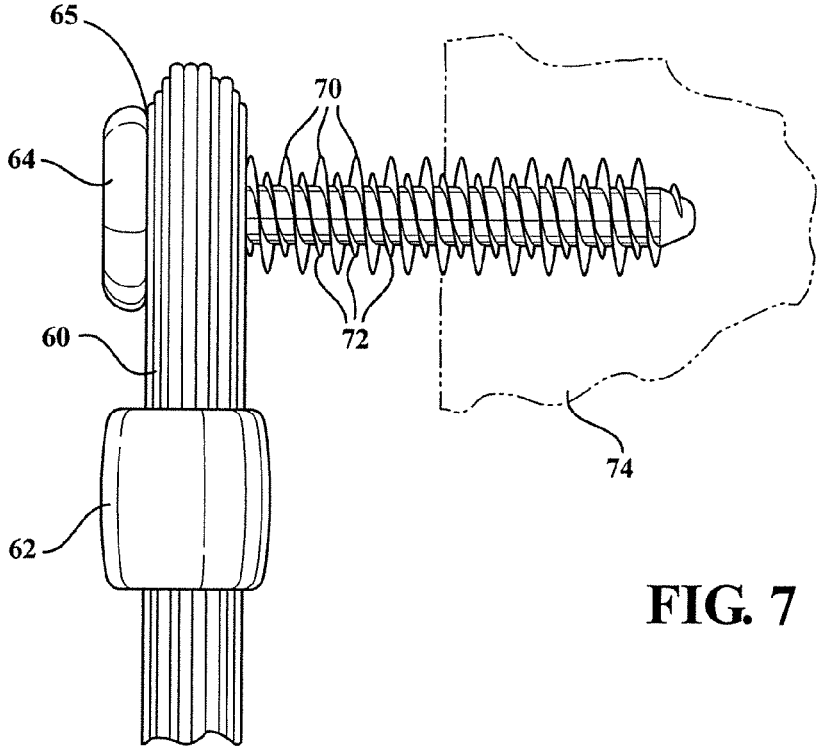
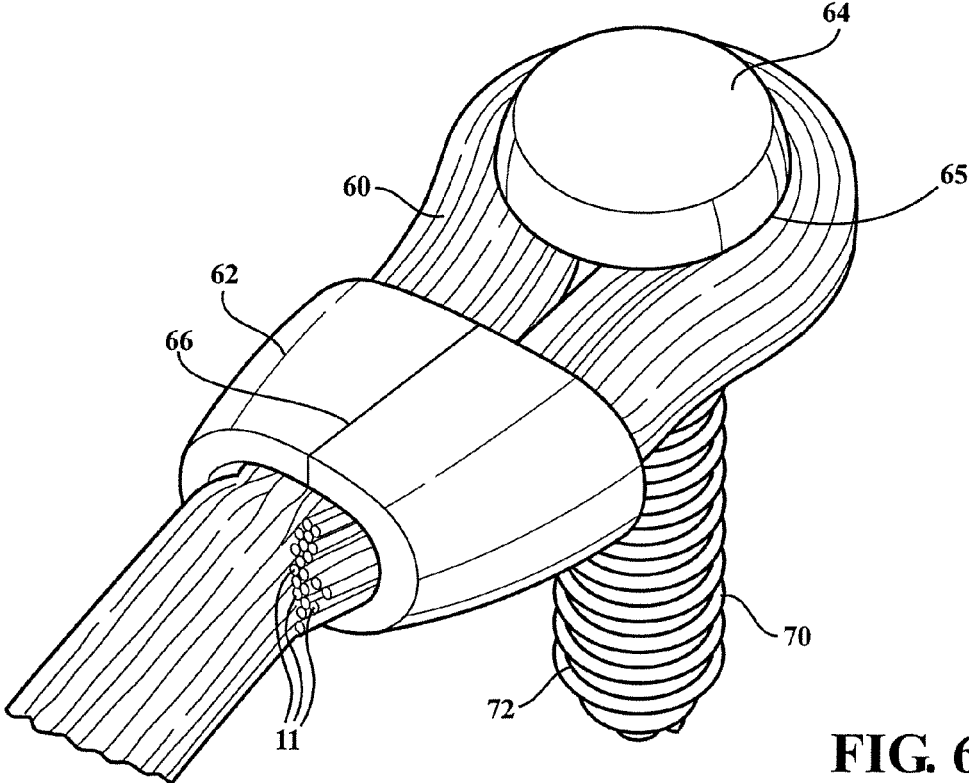

FIG. 5



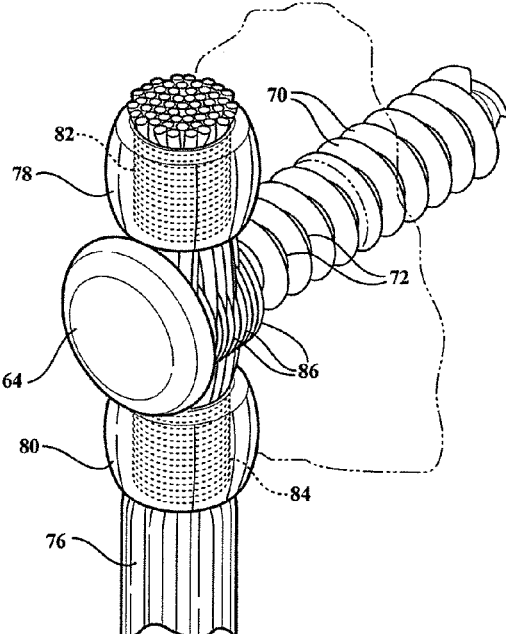

FIG. 8

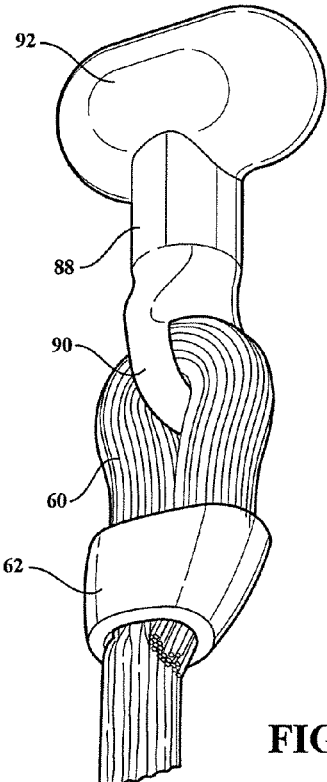
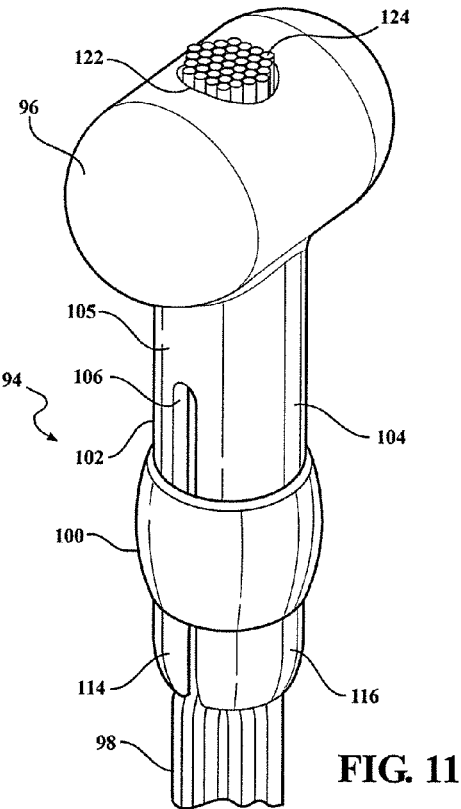
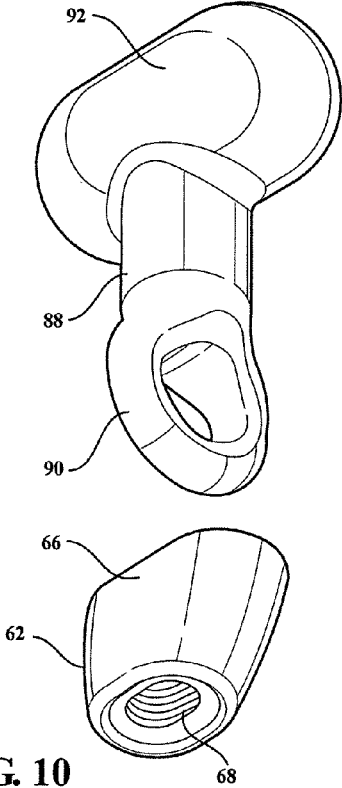

FIG. 9



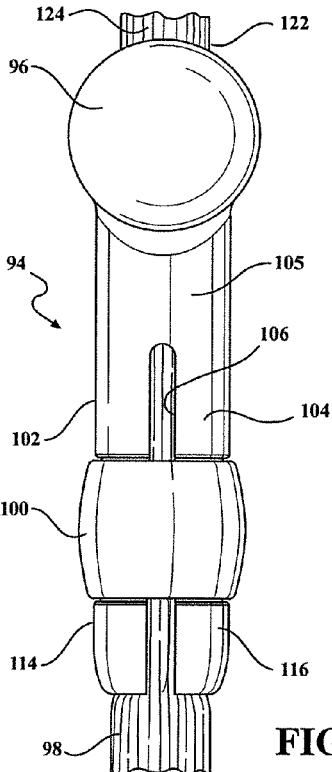

FIG. 12

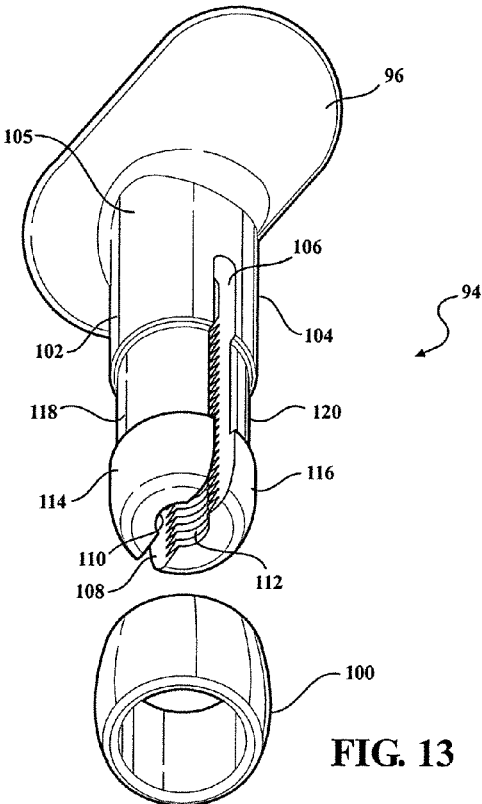

FIG. 13

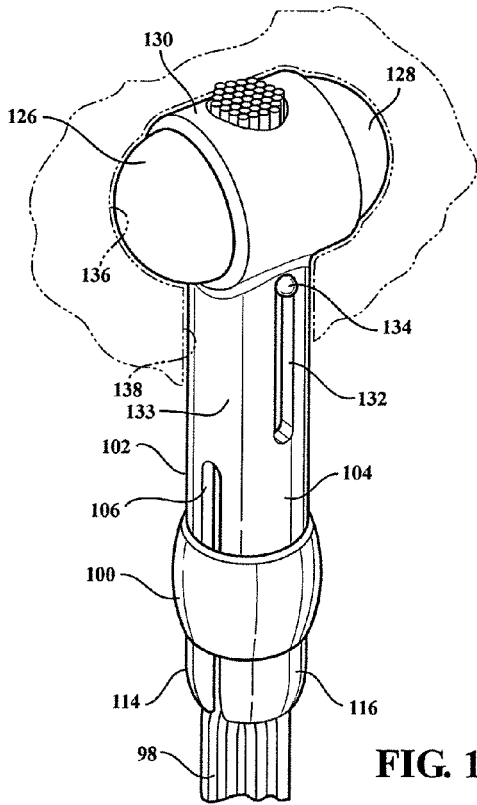

FIG. 14

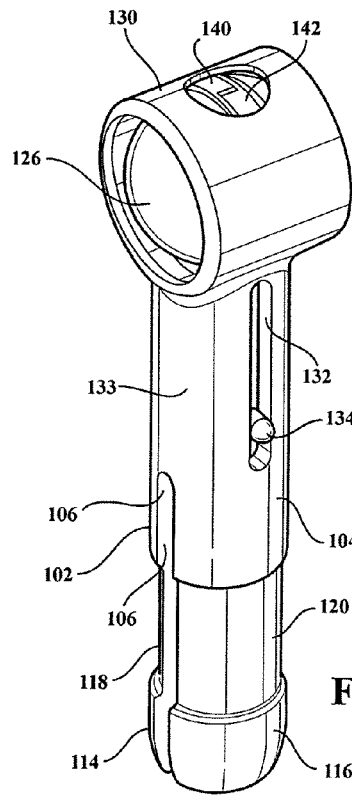

FIG. 15

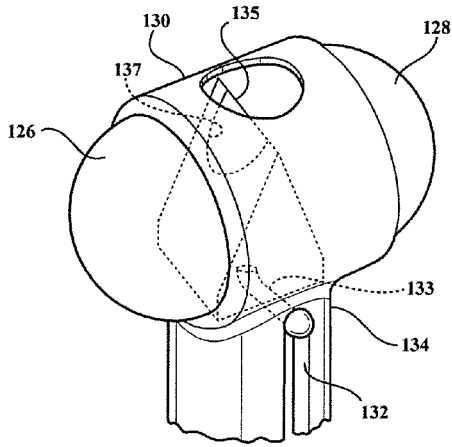

FIG. 16

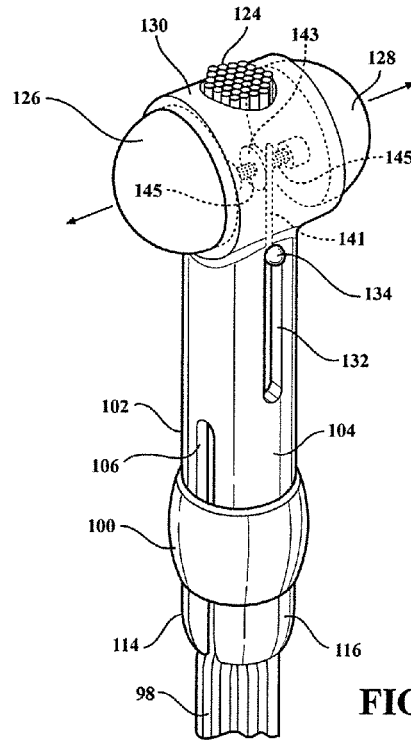

FIG. 17

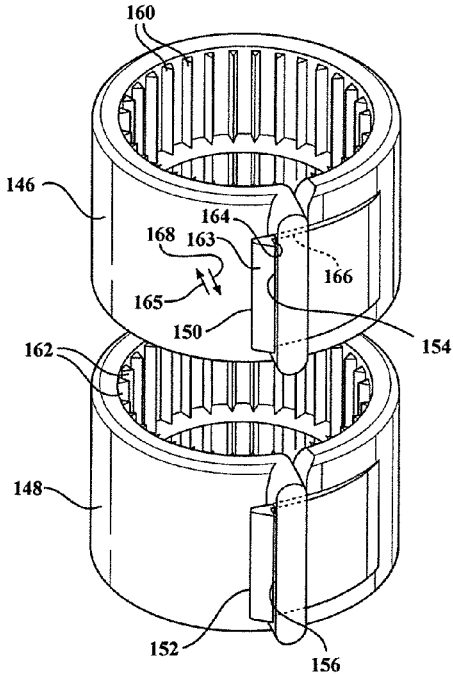

FIG. 18

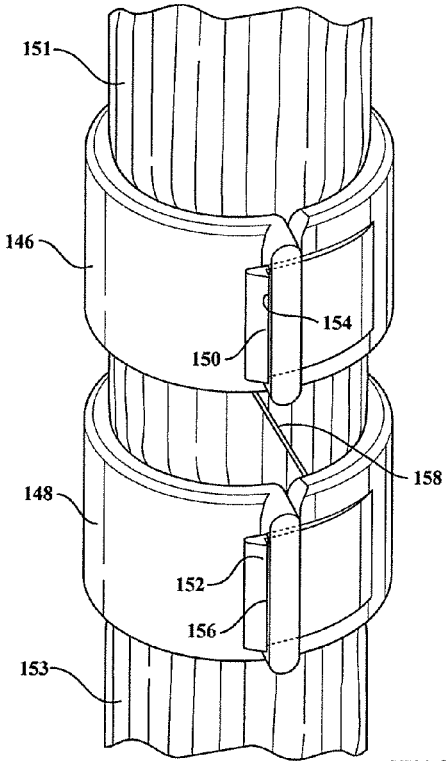
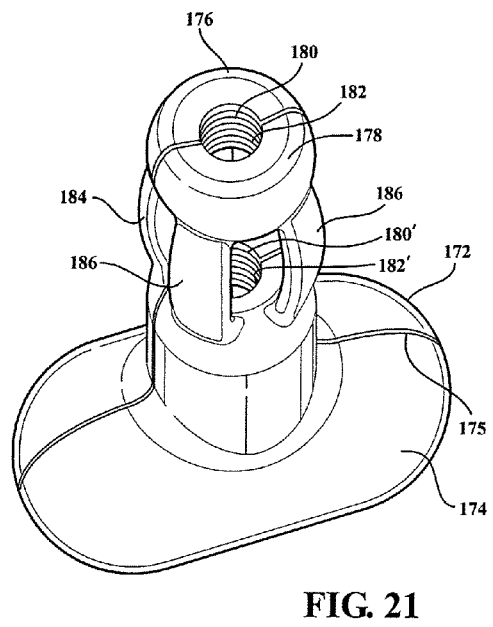
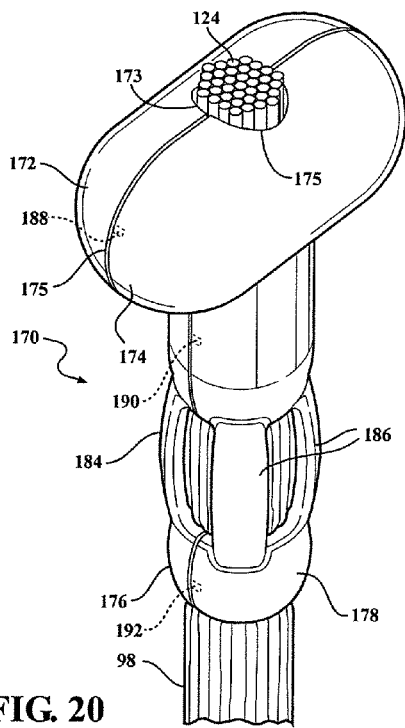

FIG. 19



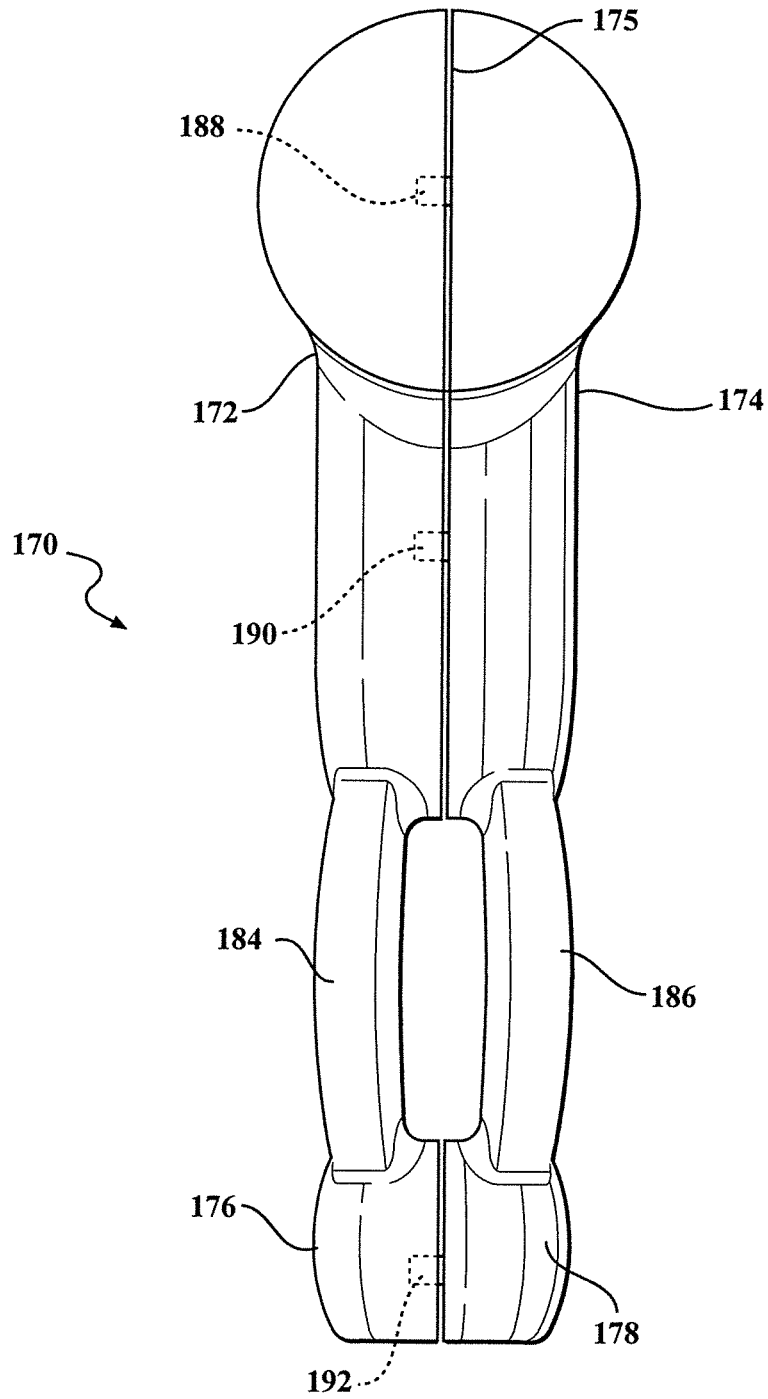

FIG. 22

CLAMPING ASSEMBLIES FOR SECURING LIGAMENTS TO A BONE

CROSS-REFERENCE TO RELATED APPLICATIONS

[0001] This Application is a Division of application Ser. No. 12/797,156 filed on Jun. 9, 2010. Application Ser. No. 12/797,156 claims the benefit of U.S. Provisional Application 61/186,215 filed on Jun. 11, 2009, the contents of which are incorporated herein in their entirety.

FIELD OF THE INVENTION

[0002] The present invention teaches various types of clamp or brace assemblies for repairing ligament damage. More specifically, the present invention discloses a variety of braces, clamps and related devices for repairing either natural or synthetic ligaments implanted within a reconditioned or replaced joint assembly.

BACKGROUND OF THE INVENTION

[0003] The prior art is documented with various assemblies for repairing or installing artificial ligaments associated with any of a repaired, reconstructed or artificially installed joint implant. A continual objective is the ability to properly size and install ligaments for ensuring long term use of the reconditioned joint.

[0004] As is known, a problem with both (natural) existing joint assemblies and artificial implanted joints is the ability to securely anchor and maintain the arrangement of ligaments which are necessary for proper joint operation. It is further known that such ligaments can be damaged apart from the associated joint application, thus requiring repair or replacement. Such artificial ligaments can include such as graphite and composite plasticized constructions, these providing the desired properties of durability combined with stretch resistance.

SUMMARY OF THE INVENTION

[0005] The present invention discloses an assembly for securing a plurality of ligaments to a bone and includes a ligament end anchor undercut clamp assembly constructed as first and second split portions which are bounded by a central and length extending parting line. A modified stem configuration which provides enhancing gripping of the plurality of ligaments, such as being of varying thicknesses.

[0006] The clamp includes first and second spaced apart and integrally formed semi-circular ring clamp portions, these further exhibiting inner knurled surfaces. Combined with intermediately positioned, length extending and circumferentially spaced arms interconnecting an upper end of the stem with the bottom located ring clamp portions, the structural supporting stem provides both enhanced gripping of the end location of the ligament bunch, such as further enhanced by the provision of the inwardly facing and knurled/serrated surfaces.

[0007] A two piece snap-fit nature of the clamp design is further depicted by spaced apart engaging tabs located at respective head, stem and bottom ring clamp locations along a selected split portion. In this fashion, the tabs biasingly engage mating locations associated with the other split portion for adjusting a spatial positioning of the first and second split portion pieces relative to one another, such as in order to accommodate differently sized ligament bunches.

BRIEF DESCRIPTION OF THE DRAWINGS

[0008] Reference will now be made to the attached drawings, when read in combination with the following detailed description, wherein like reference numerals refer to like parts throughout the several views, and in which:

[0009] FIG. 1 is an illustration of a clamping assembly for repairing damaged or broken ligaments according to a first embodiment;

[0010] FIG. 2 is an illustration of a plurality of ligaments from FIG. 1 and in which a "V" notch configuration is imparted between refashioned first and second sections of strands, this in order to maximize the holding capabilities provided by the clamping assembly in FIG. 1;

[0011] FIG. 3 is a perspective illustration of the clamping assembly of FIG. 1 in both exploded (phantom) and assembled positions;

[0012] FIG. 4 is an illustration of a modified clamping assembly incorporating a plurality of circumferential extending fastening locations;

[0013] FIG. 5 is a rotated perspective illustration of the clamping assembly in FIG. 4;

[0014] FIG. 6 illustrates an end looped plurality of ligaments mounted to a bone by a combination clamp and bone screw according to a further embodiment;

[0015] FIG. 7 is a side view illustration of the combination clamp and bone screw of FIG. 8;

[0016] FIG. 8 is a perspective illustration of another mounting arrangement for securing an end plurality of ligaments to a bone and utilizing a pair of spaced apart ring clamps, between which a bone screw pierces through a fixed section of ligaments to anchor to a bone;

[0017] FIG. 9 is a perspective illustration of an end looped plurality of ligaments mounted to a bone by a combination intermediate clamp and end positioned anchor according to a still further embodiment;

[0018] FIG. 10 is an exploded view of the clamp and end anchor of FIG. 9;

[0019] FIG. 11 is a perspective illustration of a ligament end mounting clamp according to a still further configuration and including a bone securing end-anchor integrally formed with an elongated stem for supporting about an end of the ligament bunch and which is inwardly compressible by a slidably installed ring clamp;

[0020] FIG. 12 is a side view of the installed clamp shown in FIG. 11;

[0021] FIG. 13 is an exploded perspective of the clamp assembly as depicted in FIGS. 11 and 12 and further illustrating the inwardly serrated surfaces applied along each of the lengthwise extending and linearly separated/compressible halves;

[0022] FIG. 14 is a perspective illustration of a ligament end mounting clamp similar in nature to that disclosed in FIG. 11 and further illustrating a pair of semi-spherical undercut seating portions and associated trigger mechanism for outwardly displacing the seating portions from a modified housing associated with the end anchor;

[0023] FIG. 15 is an illustration of the ligament end mounting clamp of FIG. 14 and further showing the linear displaceable trigger mechanism associated with a stem portion of the clamp retracted to withdraw the undercut seating portions inwardly within the housing, such as corresponding to an initial bone installation position of the anchor;

[0024] FIG. 16 is a succeeding illustration of the mounting clamp, similar to FIG. 14 and illustrating trigger mechanism

displaced to an upper-most position corresponding to outward actuation of the seating portions from the sleeve shaped and cross wise end extending housing;

[0025] FIG. 17 is a somewhat enlarged and corresponding view to that shown in FIG. 14;

[0026] FIG. 18 is an illustration of a pair of ring shaped clamps and illustrating inwardly defined serrated teathed patterns for enhancing its gripping properties when installed in compressing fashion over associated ligaments;

[0027] FIG. 19 is an environmental view of the pair of ligament compressing clamps depicted in FIG. 18 and further illustrating the incorporation of an angled incision defined in the opposing and mating ends of the ligament sections according to the further preferred configuration;

[0028] FIG. 20 is a perspective view of a ligament end mounting clamp according to a yet further variant and including a modified stem configuration for enhancing gripping of a plurality of ligaments of varying thicknesses;

[0029] FIG. 21 is rotated perspective view of the clamp of FIG. 20 and further showing the first and second spaced apart and integrally formed semi-circular ring clamp portions with inner knurled surfaces, combined with the intermediately positioned, length extending and circumferentially spaced arms associated with a structural supporting portion of the stem; and

[0030] FIG. 22 is a side plan view illustrating the two piece snap-fit nature of the clamp design of FIG. 20 and further showing spaced apart engaging tabs for adjusting a spatial positioning of the first and second pieces relative to differently sized ligaments.

DETAILED DESCRIPTION OF THE PREFERRED EMBODIMENTS

[0031] Referring to the several illustrations, the present invention discloses a variety of clamp and brace assemblies for repairing ligament damage. As previously described, the present invention discloses a variety of braces, clamps and related devices for repairing either natural or synthetic ligaments implanted within a reconditioned or replaced joint assembly.

[0032] Additionally, it is understood that ligament repair, reconditioning or replacement can be associated with implantation of an artificial replacement joint. In each below described example, the ability to maintain continuous and non-slipping grip of the ligament strand, combined with the disclosure of effective mechanisms for securely anchoring the ligaments to a bone location, are stressed. The present invention also discloses unique and novel techniques for notching or incising opposing and mating surfaces of first and second individual ligament bunches, these subsequently being securely clamped in place by the various assemblies described herein.

[0033] Referring first to FIGS. 1-3, a series of illustrations are provided of a clamping assembly 10 according to a first non-limiting variant for repairing damaged or broken ligaments, further depicted as first 12 and second 14 end-aligning ligament sections. As best shown in FIG. 2, the end to end aligning and connecting ligament sections (bunches) 12 and 14 are illustrated in which a "V" notch separation line configuration is imparted between refashioned and opposing end connections of the first 12 and second sections 14 strand sections, this creating an overlap configuration between the

opposing end portions of the ligament bunches and in order to maximize the holding capabilities provided by the clamping assembly 10 in FIG. 1.

[0034] The incised pattern established between the ligament bunches is shown by first end projecting and interconnecting "V" configuring surfaces 16 and 18 associated with the upper ligament bunch 12, a corresponding and mating recess pattern being further defined by additional surfaces 20 and 22 associated with the second lower bunch 14 and within which is seated the projecting profile of upper ligaments 12. Consistent with the description of FIG. 2, it is also understood that the ligament sections as described and illustrated herein envision the use of both individual (and larger diameter sized) ligaments or multiple (plural) ligament bunches, such as described throughout the several views.

[0035] As will also be described, the notching or incising of the opposing ends of the ligament sections can be fashioned in varying patterns, the purpose for which being to achieve maximum restraining and location of the sections when gripped between the clamping assembly. It is further envisioned that, in situations where a previously installed ligament is damaged, such notching and subsequent clamping is desirous in a repairing (in situ) operation where the necessary repairs to the patient can be achieved without removal or refashioning of the underlying joint assembly.

[0036] As again depicted in FIG. 1 and with further reference to FIG. 3 which illustrates both separated (phantom) and assembled (solid) positions of the clamping assembly 10, the clamping assembly can be constructed of any of a plastic, composite plastic or other hybrid material which exhibits the necessary properties of bend-ability and durability, and which further illustrates the features of first 24 and second 26 lengthwise extending and linearly/circumferentially spaced supports. A generally ring shaped clamping portion 28 is integrally formed with intermediate locations of the lengthwise supports 24 and 26.

[0037] The clamping portion 28 exhibits a generally ring shape and, dependent upon the variant, can include first and second split locations defining separable halves or (as further depicted) can define a flexible material which is opened at a single location via a first mounting end 30 and a second circumferentially opposing mounting end 32. The first mounting end 30 exhibits a tab 34 (such as further configuring a ramped or angled portion terminating in an end abutting shoulder 35) and which is engageable within a slot defined within an opposing receiving portion 36 (see further inner perimeter surface 37 which establishes the slot) associated with the second mounting end 32. In this fashion, and as is again shown in FIG. 1, the clamping assembly 10 is capable of being flexibly applied around the interconnecting interface defined between the ligament bunches 12 and 14, following which the tab 34 is engaged through the receiving portion 36.

[0038] FIG. 3 further illustrates the clamping assembly 10 in an opened position (see lengthwise supports 24 and 26 in phantom) prior to locating and securing about a repaired ligament configuration (bunches 12 and 14) such as shown in FIG. 2. In combination with the assembled configuration of FIG. 1, FIG. 3 also illustrates the manner in which the elongated supports 24 and 26 are deflected outwardly relative to the interconnecting ring shaped clamping portion 28 and prior to installing about the repair location of the end to end disposed ligament sections 12 and 14. Also included is the provision of inwardly facing and knurled (or teathed) surface patterns for providing an added measure of gripping of the

supports **24** and **26** about the ligament bunches, such as which can be incorporated into reinforced portions located at opposing and first and second end locations, see at **38 & 40** and **42 & 44** associated with the supports **24** and **26**, as well as additional knurled portions **46** extending inwardly in circumferential fashion around the inner perimeter of the ring clamp portion **28**.

[0039] In this fashion, the clamping assembly **10** can be manipulated to encircle and subsequently compress and fixedly engage the repaired ligament sections **12** and **14** without fear of the ligaments separating prior to them fusing together. It is also envisioned that the clamp can be sized to become an enduring part of the ligament repair, in particular instances, or can be removed in a subsequent operation once the break in the ligaments has completely healed.

[0040] Referring now to FIGS. **4** and **5**, an illustration is generally shown at **48** a modified clamping assembly incorporating a plurality of circumferential extending and generally ring-shaped fastening locations which generally corresponds to the assembled version of the clamping assembly **10** in FIG. **3**. Specifically, a pair of modified and lengthwise supports **50** and **52** are structurally maintained by a plurality of spaced apart, integrally formed and generally ring shaped clamping portions **54**, **56** and **58**, each of which generally corresponds in construction to the single ring-shaped clamp **28** illustrated in the variant of FIG. **1**.

[0041] As with the clamp **28**, each of the spaced apart clamping portions **54**, **56** and **58** is integrally formed with upper/lower end and intermediate locations between the lengthwise supports **50** and **52** and, identical to that described in FIG. **3** with reference to ring clamping portion **28**, each further again includes a first mounting end with a first engaging tab (see as is selected shown by tab **53** for upper clamping portion **54**) which is received within a slot defined within an opposing receiving portion (further exemplary shown by slot **55** and receiving portion **57**) associated with a second mounting end. Also again shown are respective pluralities of inner perimeter surface applied knurled or teathed surface patterns (see as shown by example at **59** for upper clamping portion **54** and which is identical to that previously illustrated at **46** in FIG. **3**), which are also identical to that identified and described in the embodiment of FIG. **3** and which facilitate compressive gripping and permanent location about the repaired ligament sections **12** and **14** also depicted in FIG. **4**.

[0042] Referring now to FIGS. **6** and **7**, both perspective and side plan views are shown of an end looped plurality of ligaments, at **60**, mounted to a bone (not shown) by a combination clamp **62** and bone screw **64** according to a further embodiment. As described previously, the ligaments **60** can be either natural or man-made and, upon being fashioned in the end-looped fashion illustrated, are fixed by application of the clamp **62**.

[0043] As further shown, the clamp **62** can exhibit a tapered or non-linear three dimensional shape to accommodate the folded over ligament end-loop and can be constructed of a plastic or other suitable material and includes a split location **66** such as permitting the clamp to be forcibly manipulated in position around the looped end of the ligaments, following which they are snap-fit or tightened such that inner facing knurled patterns (see at **68** as is also shown in FIG. **10**) engage and inwardly compress the overlapping ligament bunches. The screw **64** is pre-positioned during the initial folding of the ligament ends and is fixedly maintained about the inner looped end following installation of the clamp **62**. As further

shown in FIG. **7**, the shaft portion of the screw **64** can exhibit varying thread profiles, see as shown at **70** and **72**, this promoting gripping forces when installed within the user's bone (see as further shown in phantom at **74**)

[0044] FIG. **8** illustrates a perspective view of a further mounting arrangement for securing an end plurality of ligaments, shown at **76**, to a bone (not shown) and which utilizes a pair of spaced apart ring clamps **78** and **80**, between which a modified version of the bone screw **64** pierces through a fixed section of ligaments and in order to anchor to a specified location of the bone. The ring clamps **78** and **80** each exhibit a split configuration allowing the clamps to separate into halves during assembly around the ligaments.

[0045] Inner circumferentially extending surfaces of the clamps each further exhibit inwardly facing and accordion-like serrated patterns, see in phantom at **82** and **84** respectively, which assist in providing the necessary compressive gripping engagement about the plural ligament strands. Although not clearly shown, it is understood that the ring clamps **78** and **80** can each further consist of assembled split portions, such as further utilizing any type of snap-fit or adjustable features to ensure secure and fixed location with respect to the ligaments.

[0046] The modified anchor screw **64** can again be constructed of a plastic or composite material and is typically pre-positioned in piercing fashion through the ligament strands before installation of the split rings **78** and **80**. In combination with the varying thread patterns **70** and **72** previously described (see FIG. **7**), a further plurality of increased diameter and narrower thickness threads are shown at **86** associated with the screw **64** and function to provide enhanced gripping of the ligaments **76**, this preventing the screw **64** from inadvertently detaching from the ligaments during subsequent use and progressive fusing of the ligaments to the bone surfaces, and which is ensured by the clamping forces asserted by the adjoining ring clamps **78** and **80**.

[0047] FIGS. **9** and **10** illustrate a pair of environmental and separate perspective views, respectively of an end looped plurality of ligaments (again at **60** in FIG. **9** and referring to the previously described embodiment of FIG. **6**) and which is mounted to a bone by a combination intermediate clamp (see again at **62** and according to that previously described in FIG. **6**) as well as an end positioned anchor **88**. The anchor **88** can be constructed of a plasticized or composite plastic material which replaces the bone screw **64** associated with the previous embodiment and also includes a first aperture defined end, see lower ring **90**, for receiving the looped ligament strands **60** prior to the same be fastened to the (split ring assemble or solid one piece) clamp **62**. An upper end of the anchor **88** includes a generally dual-end bulbous shaped portion **92**, this corresponding to a recessed undercut pattern (not shown in this variant) associated with a machining process applied to an associated bone (also not shown) and to which is permanently secured the projecting portion **92** of the anchor **88**.

[0048] Referring now to FIGS. **11**, **12** and **13**, a series of illustrations are shown in perspective environmental, side assembled and perspective exploded respectively of a ligament end mounting clamp, generally at **94**, according to a still further configuration. The clamp **94** includes a bone securing undercut end-anchor assembly in the form of a projecting portion **96** (which is similar to the projection portion **92** in FIG. **10**), and which is integrally formed with an elongated

stem for supporting about an end of a ligament bunch **98** and which is inwardly compressible by a slidably installed ring clamp **100**.

[0049] The exploded view of FIG. **13** best illustrates the configuration of the anchor assembly **94** and, in addition to the undercut engaging end **96**, further shows an integrally extending stem consisting of first and second sections **102** and **104** (both extending from a common trunk **105** located in communication with an underside of the projecting portion **96**), the individually branching sections **102** and **104** further separated by a pair of linear extending slots **106** and **108**. As further shown, an inner profile of each of the stem sections **102** and **104** further exhibit a serrated pattern (at **110** and **112** in FIG. **13**) which enable the clamp assembly to be pre-positioned over the extending end of the ligament bunch **98** as shown in FIG. **11**.

[0050] At this point, the ring clamp **100**, which exhibits a generally annular shape, is installed in a progressive sliding fashion over end-most (and slightly projecting) and generally semi-cylindrical shaped portions **114** and **116** associated with the stem sections **102** and **104**, following which the ring clamp **100** seats within intermediate recessed surfaces **118** and **120** separating the end-most portions **114** and **116** with upper located portions of the stem sections **102** and **104**. The dimensions of the recessed profile (see again FIG. **13**) defined in the intermediate location of the clamp stem are such that the slidably engaged ring clamp **100** is fixedly seated in place (FIGS. **11** and **12**) while exerting a sufficient compressive holding and gripping forces against the ligament bunch **98**.

[0051] Additional features not specifically shown include the collar being height adjustable along the inwardly compressible stem in order to modify a clamping compressive force exerted on the ligament bunch. Also shown at **122** is an upper end aperture associated with the undercut engaging top end **96** through which projects a very end point of the ligament bunch, see further at **124** in FIGS. **11** and **12**, and in order to promote ligament fusion to the interior profile of the bone (not shown) within which the undercut portion **96** is anchored.

[0052] FIGS. **14-17** disclose a series of perspective illustrations of a ligament end mounting clamp, generally at **94**, according to a still further configuration similar to that previously described in FIGS. **11-13**, but in which the fixed upper end mounted undercut anchor (at **96** in FIG. **11**) has been reconfigured by the addition of a pair of semi-spherical undercut seating portions **126** and **128** and associated trigger mechanism for outwardly displacing the seating portions **126** and **128** from a modified housing **130** similar to a "T" connector like fitting associated with the end anchor. The trigger mechanism is initially identified by slot **132** positioned along a lengthened upper trunk end **133** of the interconnecting stem portion (see again lower communicating split stem sections **102** and **104**) through which the ligament bunch **98** extends.

[0053] An actuating mechanism is incorporated into an upper end of the clamp housing and is connected to a button **134** (see triangular shaped actuating mechanism **135** in phantom in FIG. **16**) seated within the slot **132** and which is actuated via a stem or rod **133** interconnecting the wedge **135** with the button **134** to travel upwardly along the length of the slot **132** concurrent with selectively upwardly/outwardly actuating or downwardly/inwardly retracting individual undercut seating portions **126** and **128**. The initial retracted position of undercut seating portions **126** and **128** within the upper end housing **130** in FIG. **15** corresponds to an initial

bone installation position of the anchor within a previously undercut location (see at **136** in FIG. **14** and which is communicated to an exterior of the bone via a narrowed neck **138**), such undercut formation being known through the implementation and manipulation of appropriate medical drilling and routing tools.

[0054] The length and width dimensions of the sleeve shaped housing **130** (with inwardly retracted seating portions **126** and **128**) is understood to be sufficient to permit insertion through the narrowed neck profile **138** of the bone. The trigger mechanism is subsequently engaged (by moving the button **134** upwardly along the slot **132**) in order to cause the internal actuating mechanism, such as again the wedge type component **135** and which can also include a cam or bevel arrangement of some type, to outwardly displace the seating portions **126** and **128** from inside the housing **130** to the position shown in FIG. **14** and in order to permanently seat and anchor the anchor assembly within the undercut configuration of the bone. It is also envisioned that the triangular/wedge shaped element **135** can also exhibit an inner aperture (see perimeter defining inner wall **137**) which permits the ligament bunch **124** to be pre-located through the interior of the wedge in the manner shown and so that the triangular wedge can be actuated without interfering with the positioning of the ligaments.

[0055] In a possible alternate arrangement to the wedge shaped component **135** depicted in FIG. **16**, another possible example of a laterally displacing mechanism is representatively illustrated in FIG. **15** (which illustrates the anchor assembly without the ligament bunch **98**) and in which are partially evident inner/opposing engaging locations **140** and **142** associated with the laterally displaceable seating portions **126** and **128**. The seating portions **126** and **128** are biased outwardly by an alternately configured cam or other type displacing portion (this being further representatively shown in selected view of FIG. **17** as including a gear rack **141** which is mechanically linked at a lower end to the trigger button **134** and which, upon traveling upwardly, rotates a gear **143**. The gear **143** in turn mounts and coaxially rotates a pair of oppositely extending and exteriorly threaded shafts **145** which are seated within internally threaded pockets defined in the base of each seating projection **126** and **128** and, upon actuating, causes the portions **126** and **128** to oppositely and outwardly separate.

[0056] As previously described with reference to the embodiment of FIGS. **11-13**, the gear actuating mechanism **143** and **145** can also be reconfigured differently than shown in FIG. **17** (such as by repositioning the rotating gear **143** and oppositely extending threaded drive shafts **145**) in such a fashion that the ligament bunch **124** can remain permanently affixed to the anchor assembly. Further, and via the split stem arrangement with inwardly teathed and serrated surfaces combined with the provision of the ring clamp **100** which forcibly engages over the lower end portions **114** and **116** associated with the split stem **102** and **104**, subsequently seats within the reduced intermediate recessed surfaces **118** and **120**, separating the end-most portions **114** and **116** with upper located portions of the stem sections **102** and **104**, this again in order to maintain a permanent gripping arrangement with the ligament bunch **98**. As also previously described, the upper projecting ends **124** of the ligament bunch **98**, being in contact with the inner undercut surface of the bone, also promote additional adhering growth to the associated bone.

[0057] FIGS. 18 and 19 disclose a pair of exploded and environmental assembled perspective views of another version ligament clamp assembly and in which a pair of ring-shaped and spaced apart clamps 146 and 148 are configured for gripping and compressing individual linear locations associated with first 151 and second 153 sections of ligaments located proximate to a damaged area. FIG. 18 is an enlarged view better showing the configuration of the pair of ligament compressing clamps 146 and 148, each of which are fairly identically constructed to the ring shaped clamp previously identified at 28 integrally incorporated into the overall clamping assembly referenced in the embodiment 10 of FIG. 1. In particular, each of the clamps 146 and 148 likewise include a first mounting end exhibiting a tab 150 and 152 (such as again further configuring a ramped or angled portion terminating in an end abutting shoulder) which is engageable within a slot 154 and 156 defined within an opposing receiving portion associated with the second mounting end.

[0058] Also illustrated is the incorporation of an angled incision, at 158, defined in the opposing and mating ends of the end to end abutting ligament sections 151 and 153 according to the further preferred configuration. As with the "V" notch configuration previously described, at 16-22 in FIG. 2, the 45° angled cut 158 referenced in FIG. 19 provides another non-limiting example of an increased surface splicing operation for creating a maximum area of inter-ligament growth or adhesion, such as during a healing process following initial reconditioning of the ligaments and application of the clamps (such as in situ within the patient).

[0059] The pair of ring shaped clamps in FIG. 18 again illustrate inwardly defined serrated teeth patterns, at 160 and 162, for enhancing its gripping properties when installed in compressing fashion over the ligament bunches 151 and 153. Upon installation, the projecting tabs 150 and 152 each include a progressing ramp (see at 163 for selected tab 152) terminating in an inner seating shoulder 164. The tab 150 is caused to deflect inwardly, see arrow 165, during passage therethrough of the ramp 163, and which is dimensioned to pass through the slot 154. Following this, an interconnected and narrowed neck 166 communicates within the slot 154 and whereby the resilient properties of the tab 150 bias it outwardly in the direction of arrow 168 to lock the clamp in place.

[0060] Referring finally to FIGS. 20-22 a related version of a ligament end anchor undercut clamp assembly, as generally shown at 170, is configured similar to that illustrated at 94 in FIG. 11, with the exception that the entire anchor (head) and stem portions are constructed as first 172 and second 174 split portions which are bounded by a central and length extending parting line 175. Also shown is a modified stem configuration which provides enhancing gripping of the plurality of ligaments 98, such as being of varying thicknesses, with extending ends of the ligaments being configured to seat in end projecting fashion through aligning and collectively aperture defining recess surfaces (see arcuate surfaces 173 and 175) associated with upper ends of the split portions as clearly shown in FIG. 20.

[0061] FIG. 21 is a rotated (underside facing) perspective view of the clamp of FIG. 20 and further shows the provision of first 176 and second 178 spaced apart and integrally formed semi-circular ring clamp portions, these further exhibiting pairs of opposing inner knurled surfaces, at 180 & 182 as well

as 180' and 182', arranged in both circumferentially defining and linearly spaced fashion. Combined with intermediately positioned, length extending and circumferentially spaced arms 184 and 186 interconnecting an upper end of the stem with the bottom located ring clamp portions 176 and 178, the structural supporting stem provides both enhanced gripping of the end location of the ligament bunch 98 (such as further enhanced by the provision of the inwardly facing and knurled/serrated surfaces).

[0062] FIG. 22 is a side plan view illustrating the two piece snap-fit nature of the clamp design of FIG. 20 and further showing the feature of spaced apart engaging tabs, at 188, 190 and 192, located at respective head, stem and bottom ring clamp locations of selected split portion 174. In this fashion, the tabs 188, 190 and 192 biasingly engage mating locations associated with the other split portion 172 for adjusting a spatial positioning of the first and second split portion pieces relative to one another, such as in order to accommodate differently sized ligament bunches.

[0063] Having described my invention, other and additional preferred embodiments will become apparent to those skilled in the art to which it pertains, and without deviating from the scope of the appended claims.

I claim:

1. A clamp assembly for engaging a bunched end of ligaments to a bone mounting location, said assembly comprising:

a pair of inter-assembleable split body portions, each defining enlarged head and extending stem portions, each of said body portions further exhibiting mating surfaces establishing a length extending parting line such that, upon assembly, said head is adapted to being mounted within a location of the bone; and

pluralities of spaced apart engaging tabs extending between said enlarged head and stem portions for engaging around the bunched ligaments supported between said split portions in compressive and retaining fashion.

2. The clamp assembly as described in claim 1, said mating surfaces further comprising recess surfaces configured within said head portions which collectively define an aperture for seating in end projecting fashion the bunched ligament ends.

3. The clamp assembly as described in claim 1, said stem portions further comprising first and second spaced apart and integrally formed semi-circular ring clamp portions.

4. The clamp assembly as described in claim 3, said semi-circular ring clamp portions each further exhibiting pairs of opposing inner knurled surfaces arranged in both circumferentially defining and linearly spaced fashion.

5. The clamp assembly as described in claim 3, said stem portions each further comprising intermediately positioned, length extending and circumferentially spaced arms interconnecting said first and second ring clamp portions.

6. The clamp assembly as described in claim 1, further comprising a plurality of three pairs of spaced apart engaging tabs located at respective head, stem and bottom ring clamp locations of a first selected split portion, said tabs biasingly engaging mating locations associated with said other selected split portion or adjusting a spatial positioning of said first and second split portion pieces relative to one another, such as in order to accommodate differently sized ligament bunches.

* * * * *